

# BUS AIR-RIDE TECHNOLOGY SUSPENSIONS



**Air-Ride Suspensions  
for Bus & Motorcoach  
Applications**



## The Leader in Air-Ride Technology

Holland has acquired over 50 years of experience in high-capacity air-ride suspensions. During that time, we designed and manufactured a wide-variety of air-ride suspensions, not only for bus and motorcoach applications, but also for commercial trucks, trailers, and motorhomes. Today, Holland continues to develop technologically advanced air-ride suspensions with emphasis on new suspension designs to address the needs of the worldwide bus and motorcoach industry.

## Bus and Motorcoach Experience

Our suspensions have been installed on buses since 1965. Today, Holland serves the worldwide bus industry, including bus and bus chassis builders in Mexico, China, India, USA, and the Middle East.

## Durable and Dependable

Holland designs and manufactures Holland Neway suspensions for tough operational environments. We produce cost effective suspension designs for bus operations that require a high level of performance, durability, and dependability.

## Quality and Integrity

All Holland Neway suspensions pass stringent design and material testing, computer simulation, and laboratory testing at Holland's Suspension Engineering Center located in Muskegon, Michigan. Our suspensions must also pass rigorous track and road course testing before being released for OEM installations.

All Holland manufacturing facilities are ISO-9000 registered with several QS-9000 registered.



# ECHNOLOGY

## The “Suspension System”

When combined to form the “suspension system” of the bus, our steer, drive, and tag axle suspensions are designed to complement each other to enhance overall performance and ride quality.

Holland Neway bus suspensions include a wide range of rated capacities. We can provide a suspension system tailored to the operational demands of your bus or motorcoach application.

## Innovative Suspension Designs

The new ADL Series drive-axle suspension is a good example of Holland’s leadership in providing the industry with innovative suspension designs. An installed ADL requires less space and is lighter weight than prior suspension designs. Yet it has performance and durability features that out-class the competition, even in tough transit bus operations.

## CAPACITY & SUSPENSION SERIES OVERVIEW

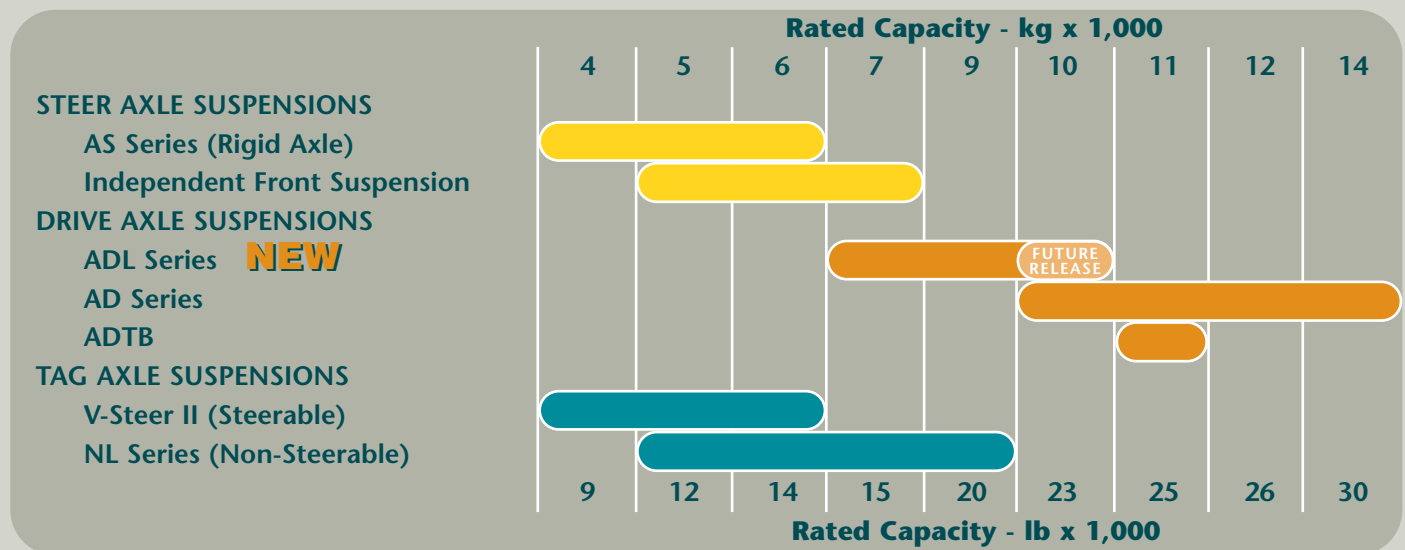

## Application and Engineering Support

Holland provides bus builders with expert application and engineering support from several Holland facilities located around the world. Our ride diagnostic services include data acquisition, analysis, and interpretation to help bus OEMs “fine tune” their suspension systems to achieve optimum performance and ride quality.



# BUS SUSPE

## STEER SUSPENSIONS



### AS SERIES

- Designed for I-beam style steer axles in rear engine bus applications.
- Air springs are positioned directly between the axle and frame for optimum ride quality and stability.
- Flexible Equalizing Beam (trailing arm) features secondary retaining strap and rubber bushed pivot connection for reliability and long service life.
- Sway bar kits are an available option.



### IFS INDEPENDENT FRONT SUSPENSION

- Wide spaced air springs provide exceptional roll stability.
- 50° wheel cut for tight vehicle turning radius.
- Dual height control valves.
- Sway bar kits are an available option.
- Integral steering gear eliminates frame mount gear.

## DRIVE AXLE SUSPENSIONS

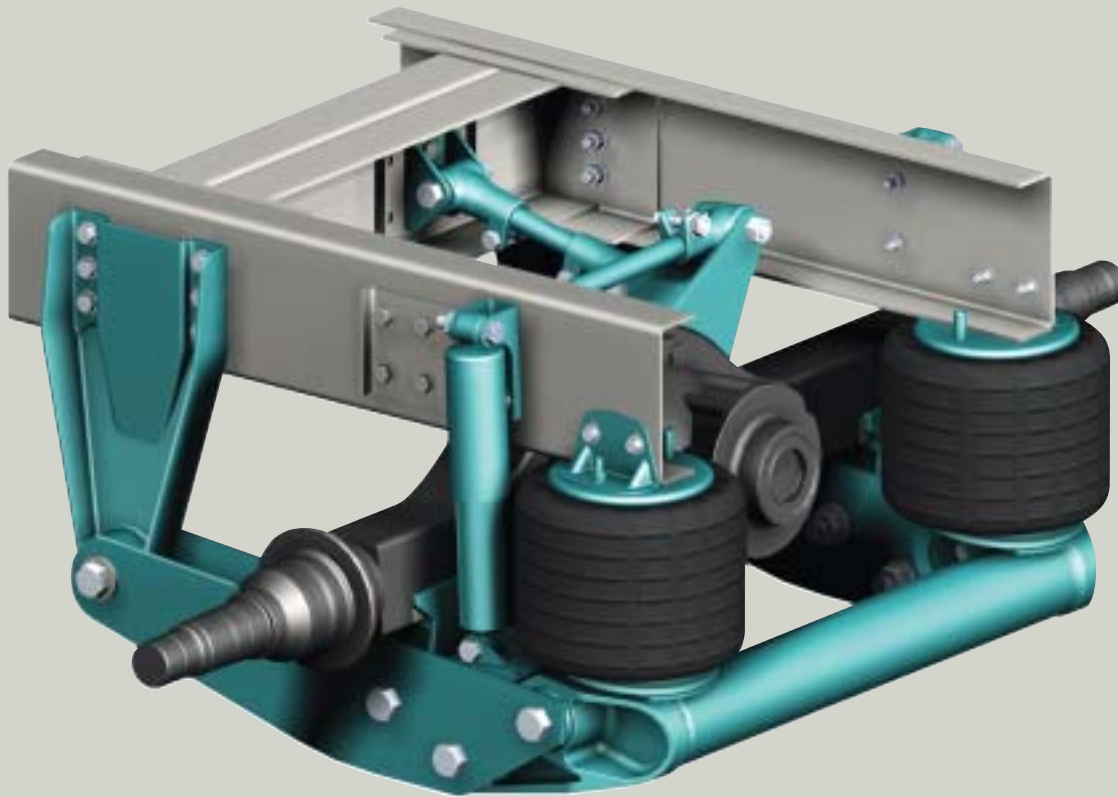

### ADL SERIES **NEW**

- **Non-torque reactive design** maintains proper pinion angle to reduce unwanted driveline vibration and noise while helping increase driveline component life.
- **Combines exceptional ride quality with high roll stability** through an integral Transverse (anti-sway) Beam that absorbs up to 85% of roll forces, protecting the axle from stress and allowing the use of softer "volumetric" air springs. The air springs feature increased air capacity by incorporating an air reservoir in the air spring pistons. This improves ride quality without the need for an external air reservoir (such as a ping tank).
- **100% rubber bushed connections** for extended service life and smooth ride. No routine maintenance or lubrication is required.
- **Shorter installed length** allows more cargo and equipment space.
- **New welded axle connection is stronger and lighter** than comparable U-bolt style connections.



## DRIVE AXLE SUSPENSIONS



### AD SERIES

- Designed for maximum durability in challenging operational environments.
- **Non-torque reactive design** maintains proper pinion angle to reduce unwanted driveline vibration and noise while helping increase driveline component life.
- **100% rubber bushed connections** for extended service life and a smooth ride. No routine maintenance or lubrication is required.
- **Integral Transverse Beam absorbs up to 85% of roll forces** to provide optimum stability while protecting the axle from excessive stress.
- **Bar-pin and through-bolt style axle connections available.**

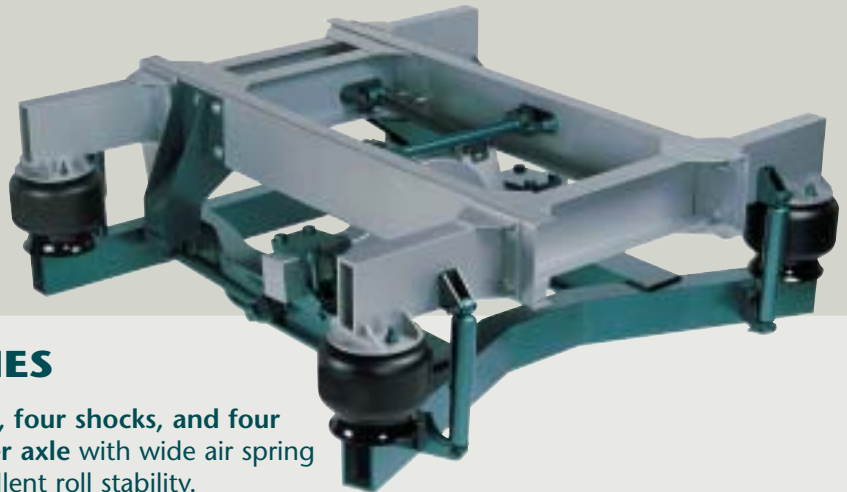

### ADTB SERIES

- **Four air springs, four shocks, and four control arms per axle** with wide air spring spacing for excellent roll stability.
- **Non-torque reactive design** maintains proper pinion angle to reduce unwanted driveline vibration and noise while helping increase driveline component life.
- **Adapts to both frame rail and monocoque type chassis constructions.**
- **Low mounting height.**
- **Patented non-weld axle connection** outperforms comparable U-bolt style connections.

# ENSIONS

## AUXILIARY TAG AXLE SUSPENSIONS



### V-STEER II

- Self-steer lift axle suspension can be configured to automatically lift in reverse.
- 27° maximum turning angle.
- "V-Arm" design provides parallelogram geometry for straight tracking.
- Standard urethane bushings and heavy-duty shocks provide durability and long service life.



### NL SERIES

- Non-steer lift axle suspension featuring high roll stiffness for increased vehicle stability.
- Available in lift and non-lift configurations.
- Design optimizes driveline clearance for rear engine bus applications and accommodates drop-center or deep-drop bent tube axles.



### HOLLAND CAN CUSTOMIZE ALL OR PART OF YOUR AIR-RIDE SUSPENSION NEEDS, INCLUDING:

- Complete Suspension Packages
- Proprietary Suspension Components
- Air Springs (specified for the application)
- Air Controls (control valves and linkages)
- Heavy-Duty Shocks (custom tuned) and Shock Mounts
- Axle Connections (welded or clamped)
- Control Arms (including double adjustable) and Control Arm Mounts
- Anti-Sway Bars and Mounts
- Suspension Sub Frames, Crossmembers, and Fastener Kits
- Frame Splicers (can be integrated with suspension Frame Brackets)
- Axle Stops

### HOLLAND NEWAY BUS SUSPENSIONS ARE COMPATIBLE WITH:

- Medium-Duty and Heavy-Duty Bus and Motorcoach Operations
  - Trolley – Commuter – Intercity
  - Shuttle – Urban Transit – Tour/Charter
  - School
- Multiple Chassis Types
  - Frame Rail or Ladder Frame Construction
  - Semi-Monocoque Construction
  - Full Monocoque Construction
- Steer and Drive Axles supplied by
  - Meritor, Dana/Eaton, Mercedes Benz, SAW, and others.
- Brakes
  - Drum Brakes - All Holland Neway suspensions are compatible.
  - Disc Brakes - Some Holland Neway suspensions are compatible with select disc brake packages. Contact your local Holland sales office for more information.



# SALES AND SERVICE OFFICES

## China

Corpco, Beijing, China  
Telephone: 86 (10) 6410-6518

## India

Holland International, Inc., Muskegon, MI, USA  
Telephone: 231-773-3271

## South East Asia

Holland Transtrade, Kuala Lumpur, Malaysia  
Telephone: 60 (0) 3-734-2888

## East Asia

Holland Transtrade Thailand, Bangkok, Thailand  
Telephone: 66 (0) 2-513-8758

## Japan/South Korea

Nippon Holland, Ltd., Tokyo, Japan  
Telephone: 81 (0) 3-3461-9130

## Australia

Holland Hitch Australia Pty., Ltd., Melton, Victoria, Australia  
Telephone: 61 (0) 3-9743-6799

## United Kingdom

Holland (Europe) UK, Ltd., Hartlebury, Worcestershire, England  
Telephone: 44 (0) 1299-254400

## Europe/MiddleEast/South Africa

Holland Europe GmbH., Schloss Holte, Germany  
Telephone: 49 (0) 5207-89560

## USA

Holland USA, Inc., Muskegon, MI USA  
Telephone: 231-773-3271

## Canada

Holland Hitch of Canada, Ltd., Woodstock, Ontario, CN  
Telephone: 519-537-3494

## Mexico

Holland International de Mexico, Mexico City, Mexico  
Telephone: 52-555-456-8641

## South America

Holland International, Inc., Muskegon, MI, USA  
Telephone: 231-773-3271

## SUSPENSION ENGINEERING CENTER & TEST LABS

Holland USA, Inc, Muskegon, MI, USA  
Phone: 231-773-3271

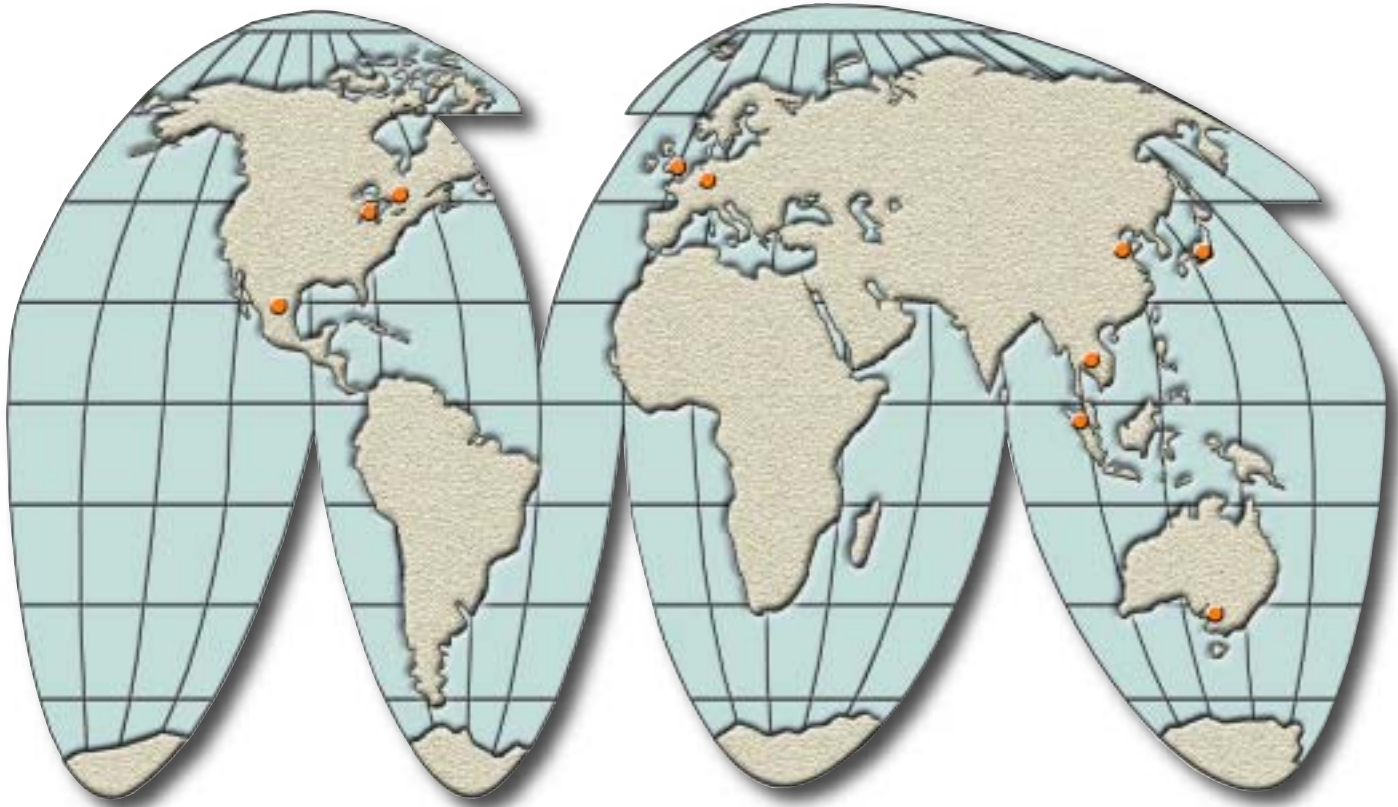

**GO THE DISTANCE.**

THE HOLLAND GROUP, INC.  
467 Ottawa Avenue • Holland, Michigan 49423 • USA  
Phone 616-396-6501 • Fax 616-356-1511  
www.thehollandgroupinc.com

Copyright © December 2002 • The Holland Group, Inc.