



RECREATIONAL VEHICLE CHASSIS MAINTENANCE MANUAL

**Models: XCL
XCR
XCP
XCS
MC**

Foreword

Scheduled maintenance provides a key element for safe operation of your vehicle. A proper maintenance program also helps to minimize downtime and to safeguard warranties. This maintenance manual provides information necessary for years of safe, reliable, and cost-efficient vehicle operation.

IMPORTANT: The maintenance operations in this manual are **not all-inclusive**. Also refer to other component and body manufacturers' instructions for specific inspection and maintenance instructions.

Perform the pretrip inspection and daily/weekly/monthly maintenance as outlined in the vehicle operator's manual. Perform the operations in this maintenance manual at scheduled intervals based upon distance traveled or months of operation. Your authorized servicing dealer has the qualified technicians and equipment to perform this maintenance for you. Your dealership can also set up a scheduled maintenance program tailored specifically to your needs. Optionally, your dealership can assist you in learning how to perform the maintenance procedures in this manual.

IMPORTANT: Descriptions and specifications in this manual were in effect at the time of printing. Freightliner Custom Chassis Corporation (FCCC) reserves the right to discontinue models and to change specifications or design at any time without notice and without incurring obligation. Descriptions and specifications contained in this publication provide no warranty, expressed or implied, and are subject to revision and editions without notice.

Refer to www.Daimler-TrucksNorthAmerica.com and www.FreightlinerChassis.com for more information, or contact Daimler Trucks North America LLC at the address below.

Environmental Concerns and Recommendations

Whenever you see instructions in this manual to discard materials, you should attempt to reclaim and recycle them. To preserve our environment, follow appropriate environmental rules and regulations when disposing of materials.

NOTICE: Parts Replacement Considerations

Do not replace suspension, axle, or steering parts (such as springs, wheels, hubs, and steering gears) with used parts. Used parts may have been subjected to collisions or improper use and have undetected structural damage.

© 2007-2008 Daimler Trucks North America LLC

All rights reserved. No part of this publication, in whole or in part, may be translated, reproduced, stored in a retrieval system, or transmitted in any form by any means, electronic, mechanical, photocopying, recording, or otherwise, without the prior written permission of Daimler Trucks North America LLC.

Daimler Trucks North America LLC
Service Systems and Documentation (POC-SSD)
P.O. Box 3849
Portland, OR 97208-3849

Descriptions of Service Publications

Daimler Trucks North America LLC distributes the following major service publications in paper and electronic (via ServicePro®) formats.

Workshop/Service Manual	Workshop/service manuals contain service and repair information for all vehicle systems and components, except for major components such as engines, transmissions, and rear axles. Each workshop/service manual section is divided into subjects that can include general information, principles of operation, removal, disassembly, assembly, installation, and specifications.
Maintenance Manual	Maintenance manuals contain routine maintenance procedures and intervals for vehicle components and systems. They have information such as lubrication procedures and tables, fluid replacement procedures, fluid capacities, specifications, and procedures for adjustments and for checking the tightness of fasteners. Maintenance manuals do not contain detailed repair or service information.
Driver's/Operator's Manual	Driver's/operator's manuals contain information needed to enhance the driver's understanding of how to operate and care for the vehicle and its components. Each manual contains a chapter that covers pre-trip and post-trip inspections, and daily, weekly, and monthly maintenance of vehicle components. Driver's/operator's manuals do not contain detailed repair or service information.
Service Bulletins	Service bulletins provide the latest service tips, field repairs, product improvements, and related information. Some service bulletins are updates to information in the workshop/service manual. These bulletins take precedence over workshop/service manual information, until the latter is updated; at that time, the bulletin is usually canceled. The service bulletins manual is available only to dealers. When doing service work on a vehicle system or part, check for a valid service bulletin for the latest information on the subject. IMPORTANT: Before using a particular service bulletin, check the current service bulletin validity list to be sure the bulletin is valid.
Parts Technical Bulletins	Parts technical bulletins provide information on parts. These bulletins contain lists of parts and BOMs needed to do replacement and upgrade procedures.
Web-based repair, service, and parts documentation can be accessed using the following applications on the AccessFreightliner.com website.	
ServicePro	ServicePro® provides Web-based access to the most up-to-date versions of the publications listed above. In addition, the Service Solutions feature provides diagnostic assistance with Symptoms Search, by connecting to a large knowledge base gathered from technicians and service personnel. Results for both documents and service solutions can be narrowed by initially entering vehicle identification data.
PartsPro	PartsPro® is an electronic parts catalog system, showing the specified vehicle's build record.
EZWiring	EZWiring™ makes Freightliner product wiring drawings and floating pin lists available online for viewing and printing. EZWiring can also be accessed from within PartsPro.

Descriptions of Service Publications

Warranty-related service information available on the AccessFreightliner.com website includes the following documentation.

Recall Campaigns

Recall campaigns cover situations that involve service work or replacement of parts in connection with a recall notice. These campaigns pertain to matters of vehicle safety. All recall campaigns are distributed to dealers; customers receive notices that apply to their vehicles.

Field Service Campaigns

Field service campaigns are concerned with non-safety-related service work or replacement of parts. All field service campaigns are distributed to dealers; customers receive notices that apply to their vehicles.

Page Description

For an example of a maintenance manual page, see Fig. 1.

A
B
C

Front Axle

33

33-01 Knuckle Pin Lubricating (See Fig. 1)

Hold a high pressure gun on each fitting until fresh grease appears. This will ensure that all the old contaminated grease has been forced out.

When lubricating knuckle pin bushings *initially* (5000 miles / 8000 km), raise the front axle until the front tires are off the ground. Wipe the lube fittings clean, and slowly feed multipurpose chassis grease (NLGI grade 1 or 2) into each bushing area while turning the wheels from extreme right to left and back again (lock to lock). This will eliminate small air pockets and improve grease distribution.

Lower the tires to the ground, and regrease both top and bottom bushings until new grease is seen at the seal on the bushing opposite the fittings. The grease seal will accept the grease pressure without damaging the seal, and is designed to have grease pumped out through it during lubrication. Even if grease leaks out around the top or bottom plate gasket, continue pumping until new grease is seen at the seal on the bushing opposite the grease fitting.

When lubricating knuckle pin bushings at indicated maintenance intervals, do not raise the front axle. Wipe the lube fittings clean, and apply multipurpose chassis

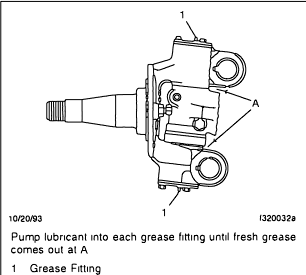

102093
Pump lubricant into each grease fitting until fresh grease comes out at A
1 Grease Fitting

Fig. 1, Mentor Front Axle

grease until new grease is seen at the grease seal on the bushing opposite the fittings

33-02 Tie-Rod End Lubricating and Inspecting

- 1 Wipe the tie-rod end grease fittings clean, then pump multipurpose chassis grease (NLGI grade 1 or 2) to the tie-rod ends until all used grease is forced out and new grease appears at the ball stud neck
- 2 Inspect the tie-rod ends
 - 2.1 Shake the cross-tube. Movement or looseness between the tapered shaft of the ball and the cross-tube socket members means that the tie-rod end assembly must be replaced
 - 2.2 The threaded portion of the tie-rod end assembly must be inserted all the way into the cross-tube split, for adequate clamping. See Fig. 2. Replace the parts if this cannot be done. For instructions, see the axle manufacturer's service manual
 - 2.3 Check the tie-rod end nut and clamp nut torques. Tighten the tie-rod end nut 100 lbf ft (136 N m), and tighten the clamp nut 40 to 55 lbf ft (54 to 75 N m)

33-03 Toe-In Inspection

For vehicle alignment to be accurate, the shop floor must be level in every direction. The turn plates for the front wheels must rotate freely without friction, and the alignment equipment must be calibrated every three months by a qualified technician from the equipment manufacturer. Freightliner dealers must have proof of this calibration history.

- 1 Apply the parking brakes, and chock the rear tires
- 2 Raise the front of the vehicle until the tires clear the ground. Check that the safety stands will support the combined weight of the cab, axle, and frame. Place safety stands under the axle
- 3 Using spray paint or a piece of chalk, mark the entire center rib of each front tire

D
E

Recreational Vehicle Chassis Maintenance Manual, March 1998
33/1

11/11/2002

A. Maintenance Operation Number consists of the Group Number followed by the Sequence Number
 B. Group Title
 C. Group Number
 D. Release Date
 E. Group Number/Page Number

Fig. 1, Example of a Maintenance Manual Page

Group No.	Group Title
00	General Information
01	Engine
09	Air Intake
15	Alternators and Starters
20	Engine Cooling/Radiator
26	Transmission
30	Throttle Control
31	Frame and Frame Components
32	Suspension
33	Front Axle
35	Rear Axle
40	Wheels and Tires
41	Driveline
42	Brakes
46	Steering
47	Fuel
49	Exhaust
54	Electrical
83	Heater and Air Conditioner

Title of Maintenance Operation (MOP)	MOP Number
General Maintenance Schedule Information.	00-01
Metric/U.S. Customary Conversion Tables.	00-05
Noise Emission Controls Maintenance.	00-03
Torque Specifications Tables.	00-06
Vehicle Maintenance Schedule Table	00-02
Verification of Inspections Log.	00-04

General Maintenance Schedule Information

Performing regular maintenance on your vehicle will help ensure that your vehicle delivers safe reliable service and optimum performance for years to come. Failure to follow a regular maintenance program can result in inefficient operation and unscheduled down time.

When the vehicle reaches the distance or time (whichever comes first) given for a maintenance interval, see the Vehicle Maintenance Schedule Table for a list of the maintenance operations to be performed at that maintenance interval. Use the maintenance operation reference numbers to find detailed instructions in the manual for each operation.

NOTE: Maintenance instructions in this manual are based on average vehicle use and normal operating conditions. Unusual vehicle operating conditions may require service at more frequent intervals.

For specific engine maintenance information, see the *Cummins* or the *Mercedes Benz Operation and Maintenance Manual*.

IMPORTANT: Maintenance operations appearing in italics in the following tables are for emission control components. Numbers in the table are reference numbers matching those in the text of this manual.

Vehicle Maintenance Schedule Table: 00–02

Maintenance Operation Set	Maintenance Intervals*			
	Frequency	Miles	km	Months
Initial Maintenance (IM)	first	6000	10 000	6
Maintenance 1 (M1)	every	6000	10 000	6
Maintenance 2 (M2)	every	12,000	20 000	12
Maintenance 3 (M3)	every	24,000	40 000	24

* Use distance or time, whichever comes first.

Maintenance Operation Procedures and Intervals				
REQUIRED MAINTENANCE OPERATION SET	IM	M1	M2	M3
Maintenance Operation Number and Description				
01–01 Engine Drive Belt Inspecting	•	•	•	•
01–02 Engine-Support Fasteners Checking				•
01–03 Pacbrake Inspecting and Maintenance*				
09–01 Air Cleaner Inspecting and Replacing				•
09–02 Charge Air Cooler Inspecting and Cleaning	•	•	•	•
15–01 Alternator, Battery, and Starter Checking			•	•
20–01 Radiator Cap Checking			•	•
20–02 Radiator Inspecting and Cleaning	•	•	•	•
20–03 Coolant Replacing†				
26–01 Transmission Breather Checking			•	•
26–02 Allison MD/MH Series Transmission Fluid Level Checking	•	•	•	•
26–03 Allison MD/MH Series Transmission Fluid and Filter Changing (internal/external filter)‡				
30–01 Throttle Pedal Pivot Pin Lubricating			•	•
31–01 Frame Fastener Torque Checking	•		•	•
32–01 Neway Suspension Fastener Torque Checking	•			•
32–02 Neway Suspension Height Control Valve Checking	•	•	•	•
32–03 Neway Suspension Inspecting	•	•	•	•
32–04 Neway Suspension Lubricating	•	•	•	•
32–05 ZF IFS Lubricating	•	•	•	•
32–06 Suspension Inspecting (front-engine diesel chassis)	•	•	•	•
32–07 Suspension U-Bolt Torque Checking (front-engine diesel chassis)	•	•	•	•
33–01 Knuckle Pin Lubricating	•	•	•	•
33–02 Tie-Rod End Lubricating and Inspecting	•	•	•	•
33–03 All-Axle Alignment Checking	•			
33–04 Wheel Bearing Removal, Cleaning, Checking, Repacking, and Adjusting				•

Vehicle Maintenance Schedule Table: 00-02

Maintenance Operation Procedures and Intervals				
REQUIRED MAINTENANCE OPERATION SET	IM	M1	M2	M3
Maintenance Operation Number and Description				
33-05 Oil-Filled Hubs Oil Level Checking	•	•	•	
33-06 Oil-Filled Hubs Oil Changing				•
35-01 Axle Lubricant Checking		•		
35-02 Axle Lubricant Changing	•		•	•
35-03 Axle Breather Checking	•	•	•	•
40-01 Wheel Nut Checking	•			•
40-02 Wheel Cleaning and Polishing [§]				
41-01 Driveline Inspecting and Lubricating	•	•	•	•
42-01 Brake System Valves Inspecting	•	•	•	•
42-02 Air Dryer Inspecting	•		•	•
42-03 Air Dryer Desiccant and Coalescent Filter Replacing [¶]				
42-04 Camshaft Bracket Bushing Lubricating			•	•
42-05 Slack Adjuster Lubricating	•	•	•	•
42-06 Foot Brake Valve Actuator Lubricating	•		•	•
42-07 Meritor Roller Pin Lubricating	•	•	•	•
42-08 Bendix Hydro-Max [®] Power Booster Checking (front-engine diesel chassis)	•	•	•	•
42-09 Brake Caliper Slide Pin Lubricating, Bosch Brakes (front-engine diesel chassis)**				
42-10 Brake Lines Checking, Hydraulic Disc Brakes (front-engine diesel chassis)	•	•	•	•
42-11 Brake Lining Wear Checking, Hydraulic Disc Brakes (front-engine diesel chassis)	•	•	•	•
42-12 Brake Inspecting	•			
46-01 Drag Link Lubricating	•	•	•	•
46-02 Power Steering Reservoir Fluid Level Checking	•	•		
46-03 Power Steering Reservoir Fluid and Filter Changing ^{††}			•	•
46-04 Steering Driveline Lubricating	•	•	•	•
46-05 Steering Gear Lubricating	•	•	•	•
46-06 Hydraulic Reservoir Filter Changing (metal reservoir only)	•			•
47-01 Fuel Tank Mounts and Fuel Line Checking	•			•
47-02 Fuel/Water Separator Element Replacing ^{‡‡}				
47-03 Inline Fuel Strainer Replacing, Cummins ISB02 Engine			•	•
49-01 Exhaust System Inspecting			•	•
54-01 Ground Cables Checking and Cleaning			•	•
54-02 Battery Voltage Checking	•	•	•	•

Vehicle Maintenance Schedule Table: 00–02

Maintenance Operation Procedures and Intervals				
REQUIRED MAINTENANCE OPERATION SET	IM	M1	M2	M3
Maintenance Operation Number and Description				
83–01 Air Conditioner Inspecting	•	•	•	•

* With frequent use, the Pacbrake Exhaust Brake will operate free of maintenance. However, if the vehicle is used inconsistently, seasonally, or is exposed to excess moisture, it will be necessary to perform preventative maintenance as instructed in Maintenance Operation **01–03**.

† Beginning with model-year 2002 RV chassis, the coolant replacement interval is increased to 100,000 miles (161 000 km) or 60 months. You must check and, if necessary, recharge the SCA (supplemental coolant additive) levels and freeze point every 25,000 miles (40 000 km) or 6 months. See the Cummins Operation and Maintenance Manual for further information.

‡ For oil and filter change intervals, see the applicable Allison Operator's Manual.

§ Perform these steps each time the wheels and/or the vehicle is washed.

¶ Replace the Bendix AD9 filter and the Haldex (Midland) PURest® air dryer filter kit every 36 months.

** Lubricate every 6 months OR every 18,000 miles (28 000 km), whichever comes first.

†† Change the TRW inline power steering filter every 12 months.

‡‡ See the Cummins Operation and Maintenance Manual for fuel/water separator element replacing intervals.

Table 1, Maintenance Operation Procedures and Schedule

Noise Emission Control Maintenance

Federal Law, Part 205: Transportation Equipment Noise Emission Controls

Part 205, Transportation Equipment Noise Emission Controls, requires the vehicle manufacturer to furnish, with each new vehicle, such written instructions for the proper maintenance, use, and repair of the vehicle by the ultimate purchaser to provide reasonable assurance of the elimination or minimization of noise-emission-control degradation throughout the life of the vehicle. In compliance with the law, the noise emission controls maintenance information in each applicable group of this manual, in conjunction with the chassis workshop manual, provides these instructions to owners.

Recommendations for Replacement Parts

Replacement parts used for maintenance or repair of noise emission controls should be genuine Freightliner Custom Chassis Corporation (FCCC) parts. If other than genuine FCCC parts are used for replacement or repair of components affecting noise emission control, the owner should be sure that such parts are warranted by their manufacturer to be equivalent to genuine FCCC parts in performance and durability.

Freightliner Noise Emission Controls Warranty

See the vehicle owner's warranty information book for warranty information concerning noise emission controls.

Tampering With Noise Controls is Prohibited

Federal law prohibits the following acts or the causing thereof:

1. The removal or rendering inoperative by any person (other than for purposes of maintenance, repair, or replacement) of any device or element

of design incorporated into any new vehicle for the purpose of noise control, prior to its sale or delivery to the ultimate purchaser, or while it is in use.

2. The use of the vehicle after such device or element of design has been removed or rendered inoperative by any person.

Among those acts presumed to constitute tampering are the acts listed below:

- A. Removal of, or rendering inoperative, the engine speed governor so as to allow engine speed to exceed manufacturer's specifications.
- B. Removal of, or rendering inoperative, the fan clutch, including bypassing the control on any thermostatic fan drive to cause it to operate continuously.
- C. Removal of the fan shroud.
- D. Removal of, or rendering inoperative, exhaust components, including exhaust pipe clamping.
- E. Removal of air intake components.

Maintenance Instructions

Scheduled intervals are in the maintenance table in this group. A "Verification of Inspections Log (Group 49)" follows, and should be filled in each time noise emission controls on the vehicle are maintained or repaired.

Verification of Inspections Log: 00–04

Verification of Inspections Log

Verification of Inspections Log, Group 49				
Date	Mileage	Item	Cost	Maintenance Facility
Group 49—Exhaust System Components				

Metric/U.S. Customary Conversion Tables: 00–05

When You Know U.S. Customary	Multiply By	To Get Metric	When You Know Metric	Multiply By	To Get U.S. Customary
Length					
inches (in)	25.4	millimeters (mm)		0.03937	inches (in)
inches (in)	2.54	centimeters (cm)		0.3937	inches (in)
feet (ft)	0.3048	meters (m)		3.281	feet (ft)
yards (yd)	0.9144	meters (m)		1.094	yards (yd)
miles (mi)	1.609	kilometers (km)		0.6215	miles (mi)
Area					
square inches (in ²)	645.16	square millimeters (mm ²)		0.00155	square inches (in ²)
square inches (in ²)	6.452	square centimeters (cm ²)		0.155	square inches (in ²)
square feet (ft ²)	0.0929	square meters (m ²)		10.764	square feet (ft ²)
Volume					
cubic inches (in ³)	16387.0	cubic millimeter (mm ³)		0.000061	cubic inches (in ³)
cubic inches (in ³)	16.387	cubic centimeters (cm ³)		0.06102	cubic inches (in ³)
cubic inches (in ³)	0.01639	liters (L)		61.024	cubic inches (in ³)
fluid ounces (fl oz)	29.54	milliliters (mL)		0.03381	fluid ounces (fl oz)
pints (pt)	0.47318	liters (L)		2.1134	pints (pt)
quarts (qt)	0.94635	liters (L)		1.0567	quarts (qt)
gallons (gal)	3.7854	liters (L)		0.2642	gallons (gal)
cubic feet (ft ³)	28.317	liters (L)		0.03531	cubic feet (ft ³)
cubic feet (ft ³)	0.02832	cubic meters (m ³)		35.315	cubic feet (ft ³)
Weight/Force					
ounces (av) (oz)	28.35	grams (g)		0.03527	ounces (av) (oz)
pounds (av) (lb)	0.454	kilograms (kg)		2.205	pounds (av) (lb)
U.S. tons (t)	907.18	kilograms (kg)		0.001102	U.S. tons (t)
U.S. tons (t)	0.90718	metric tons (t)		1.1023	U.S. tons (t)
Torque/Work Force					
inch–pounds (lbf·in)	11.298	Newton–centimeters (N·cm)		0.08851	inch–pounds (lbf·in)
foot–pounds (lbf·ft)	1.3558	Newton–meters (N·m)		0.7376	foot–pounds (lbf·ft)
Pressure/Vacuum					
inches of mercury (inHg)	3.37685	kilo Pascals (kPa)		0.29613	inches of mercury (inHg)
pounds per square inch (psi)	6.895	kilo Pascals (kPa)		0.14503	pounds per square inch (psi)

Table 2, Metric/U.S. Customary Conversion

When You Know	Subtract	Then Divide By	To Get	When You Know	Multiply By	Then Add	To Get
degrees Fahrenheit (°F)	32	1.8	degrees Celsius (°C)	degrees Celsius (°C)	1.8	32	degrees Fahrenheit (°F)

Table 3, Temperature Conversion

Torque Specifications Tables: 00–06

IMPORTANT: Grade 8 regular hex zinc-yellow plated capscrews and cadmium- and wax-coated prevailing torque locknuts may be tightened to a lower torque value than the grade 8 regular hex fasteners de-

scribed in [Table 4](#). See [Table 5](#) for torque values for grade 8 regular hex zinc-yellow plated capscrews and cadmium- and wax-coated prevailing torque locknuts.

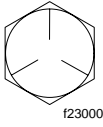
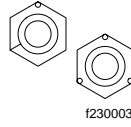
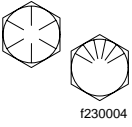
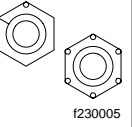
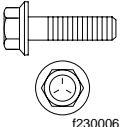
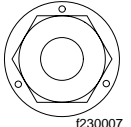
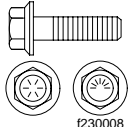
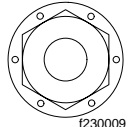
Torque Values for U.S. Customary Thread Fasteners With Lubricated* or Plated Threads†								
Thread Diameter–Pitch	Regular Hex				Flanged			
	Grade 5 Bolt	Grade 5 or B Nut	Grade 8 or 8.2 Bolt	Grade 8 or C Nut	Grade 5 Bolt	Grade B Nut	Grade 8 or 8.2 Bolt	Grade G Nut
	Torque: lbf-ft (N-m)		Torque: lbf-ft (N-m)		Torque: lbf-ft (N-m)		Torque: lbf-ft (N-m)	
	 f230002	 f230003	 f230004	 f230005	 f230006	 f230007	 f230008	 f230009
1/4–20	7 (9)		8 (11)		6 (8)		10 (14)	
1/4–28	8 (11)		9 (12)		7 (9)		12 (16)	
5/16–18	15 (20)		16 (22)		13 (18)		21 (28)	
5/16–24	16 (22)		17 (23)		14 (19)		23 (31)	
3/8–16	26 (35)		28 (38)		23 (31)		37 (50)	
3/8–24	30 (41)		32 (43)		25 (34)		42 (57)	
7/16–14	42 (57)		45 (61)		35 (47)		60 (81)	
7/16–20	47 (64)		50 (68)		40 (54)		66 (89)	
1/2–13	64 (87)		68 (92)		55 (75)		91 (123)	
1/2–20	72 (98)		77 (104)		65 (88)		102 (138)	
9/16–12	92 (125)		98 (133)		80 (108)		130 (176)	
9/16–18	103 (140)		110 (149)		90 (122)		146 (198)	
5/8–11	128 (173)		136 (184)		110 (149)		180 (244)	
5/8–18	145 (197)		154 (209)		130 (176)		204 (277)	
3/4–10	226 (306)		241 (327)		200 (271)		320 (434)	
3/4–16	253 (343)		269 (365)		220 (298)		357 (484)	
7/8–9	365 (495)		388 (526)		320 (434)		515 (698)	
7/8–14	402 (545)		427 (579)		350 (475)		568 (770)	
1–8	—		582 (789)		—		—	
1–12	—		637 (863)		—		—	
1–14	—		652 (884)		—		—	

* Freightliner recommends that all plated and unplated fasteners be coated with oil before installation.

† Use these torque values if either the bolt or nut is lubricated or plated (zinc-phosphate conversion-coated, cadmium-plated, or waxed).

Table 4, Torque Values for U.S. Customary Thread Fasteners With Lubricated or Plated Threads

Torque Specifications Tables: 00–06

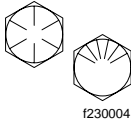
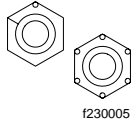
Torque Values for Grade 8 Regular Hex Zinc-Yellow Plated Capscrews and Cadmium- and Wax-Coated Prevailing Torque Locknuts*		
Thread Diameter-Pitch	Regular Hex	
	Grade 8 or 8.2 Bolt	Grade 8 or C Nut
	Torque: lbf-ft (N-m)	
		
1/4–20	6 (8)	
1/4–28	7 (9)	
5/16–18	13 (18)	
5/16–24	14 (19)	
3/8–16	23 (31)	
3/8–24	26 (35)	
7/16–14	37 (50)	
7/16–20	41 (56)	
1/2–13	56 (76)	
1/2–20	63 (85)	
9/16–12	81 (110)	
9/16–18	90 (122)	
5/8–11	112 (152)	
5/8–18	126 (171)	
3/4–10	198 (268)	
3/4–16	221 (300)	
7/8–9	319 (433)	
7/8–14	352 (477)	
1–8	479 (649)	
1–12	524 (710)	
1–14	537 (728)	

* Freightliner recommends that all plated and unplated fasteners be coated with oil before installation.

Table 5, Torque Values for Grade 8 Regular Hex Zinc-Yellow Plated Capscrews and Cadmium- and Wax-Coated Prevailing Torque Locknuts

Torque Specifications Tables: 00–06

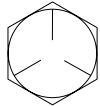
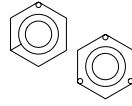
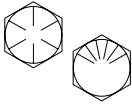
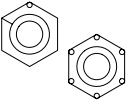
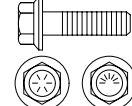
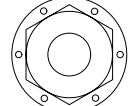
Torque Values for U.S. Customary Thread Fasteners With Dry (Unlubricated)* Plain (Unplated) Threads†						
Thread Diameter–Pitch	Regular Hex				Flanged	
	Grade 5 Bolt	Grade 5 or B Nut	Grade 8 or 8.2 Bolt	Grade 8 or C Nut	Grade 8 or 8.2 Bolt	Grade G Nut
	Torque: lbf-ft (N·m)		Torque: lbf-ft (N·m)		Torque: lbf-ft (N·m)	
	 f230002	 f230003	 f230004	 f230005	 f230008	 f230009
1/4–20	8 (11)		10 (14)		—	
1/4–28	9 (12)		12 (16)		—	
5/16–18	15 (20)		22 (30)		22 (30)	
5/16–24	17 (23)		25 (34)		—	
3/8–16	28 (38)		40 (54)		40 (54)	
3/8–24	31 (42)		45 (61)		—	
7/16–14	45 (61)		65 (88)		65 (88)	
7/16–20	50 (68)		70 (95)		—	
1/2–13	70 (95)		95 (129)		95 (129)	
1/2–20	75 (102)		110 (149)		—	
9/16–12	100 (136)		140 (190)		140 (190)	
9/16–18	110 (149)		155 (210)		—	
5/8–11	135 (183)		190 (258)		190 (258)	
5/8–18	155 (210)		215 (292)		—	
3/4–10	240 (325)		340 (461)		340 (461)	
3/4–16	270 (366)		380 (515)		—	
7/8–9	385 (522)		540 (732)		—	
7/8–14	425 (576)		600 (813)		—	
1–8	580 (786)		820 (1112)		—	
1–12	635 (861)		900 (1220)		—	
1–14	650 (881)		915 (1241)		—	

* Threads may have residual oil, but will be dry to the touch.

† Male and female threads (bolt and nut) must both be unlubricated and unplated; if either is plated or lubricated, use [Table 4](#). Freightliner recommends that all plated and unplated fasteners be coated with oil before installation.

Table 6, Torque Values for U.S. Customary Thread Fasteners With Dry (Unlubricated) Plain (Unplated) Threads

Torque Specifications Tables: 00–06

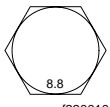
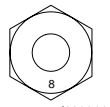
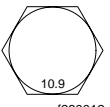
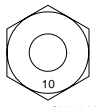
Torque Values for Metric Thread Fasteners With Lubricated* or Plated Threads†				
Thread Diameter–Pitch	Class 8.8 Bolt	Class 8 Nut	Class 10.9 Bolt	Class 10 Nut
	Torque: lbf·ft (N·m)		Torque: lbf·ft (N·m)	
				
	f230010	f230011	f230012	f230013
M6	5 (7)		7 (9)	
M8	12 (16)		17 (23)	
M8 x 1	13 (18)		18 (24)	
M10	24 (33)		34 (46)	
M10 x 1.25	27 (37)		38 (52)	
M12	42 (57)		60 (81)	
M12 x 1.5	43 (58)		62 (84)	
M14	66 (89)		95 (129)	
M14 x 1.5	72 (98)		103 (140)	
M16	103 (140)		148 (201)	
M16 x 1.5	110 (149)		157 (213)	
M18	147 (199)		203 (275)	
M18 x 1.5	165 (224)		229 (310)	
M20	208 (282)		288 (390)	
M20 x 1.5	213 (313)		320 (434)	
M22	283 (384)		392 (531)	
M22 x 1.5	315 (427)		431 (584)	
M24	360 (488)		498 (675)	
M24 x 2	392 (531)		542 (735)	
M27	527 (715)		729 (988)	
M27 x 2	569 (771)		788 (1068)	
M30	715 (969)		990 (1342)	
M30 x 2	792 (1074)		1096 (1486)	

* Freightliner recommends that all plated and unplated fasteners be coated with oil before installation.

† Use these torque values if either the bolt or nut is lubricated or plated (zinc-phosphate conversion-coated, cadmium-plated, or waxed).

Table 7, Torque Values for Metric Thread Fasteners With Lubricated or Plated Threads

Title of Maintenance Operation (MOP)	MOP Number
Engine Drive Belt Inspecting	01-01
Engine-Support Fasteners Checking	01-02
Pacbrake Inspecting and Maintenance	01-03

01-01 Engine Drive Belt Inspecting

WARNING

The engine and the belt must be cool before you check the belt. Handling a hot belt can cause personal injury.

1. Inspect the belt for damage.
 - Transverse (across the belt width) cracks are acceptable.
 - Longitudinal (direction of belt length) cracks that intersect with transverse cracks are not acceptable.
2. Replace the belt if it has unacceptable cracks, is frayed, or has pieces of material missing.
 - For additional information, see the *Cummins* or *Mercedes-Benz Operation and Maintenance Manual*.

01-02 Engine-Support Fasteners Checking

Mounts should be inspected when the engine is removed for service. Perform the following check.

1. Check the rear engine-support fasteners. See [Fig. 1](#). Tighten the rear engine-mount bolt 157 lbf-ft (213 N·m).
 - Tighten the insulator-to-frame mount bracket bolts 91 lbf-ft (123 N·m).
 - Tighten the engine mount bracket-to-engine bolts 62 lbf-ft (84 N·m).
2. Check the 3/4-10 front engine-mount bolt. See [Fig. 2](#). Tighten it 95 lbf-ft (128 N·m).
 - Check the 3/4-10 front engine-mount bolt. Tighten it 95 lbf-ft (128 N·m).

01-03 Pacbrake Inspecting and Maintenance

With frequent use, the Pacbrake Exhaust Brake will operate free of maintenance. However, if the vehicle is used inconsistently, seasonally, or is exposed to

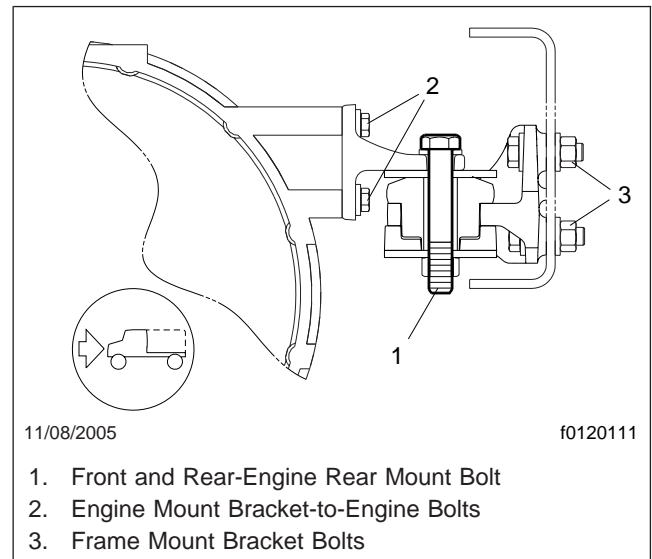

Fig. 1, Front and Rear-Engine Rear Mount (ISB chassis built after 2002)

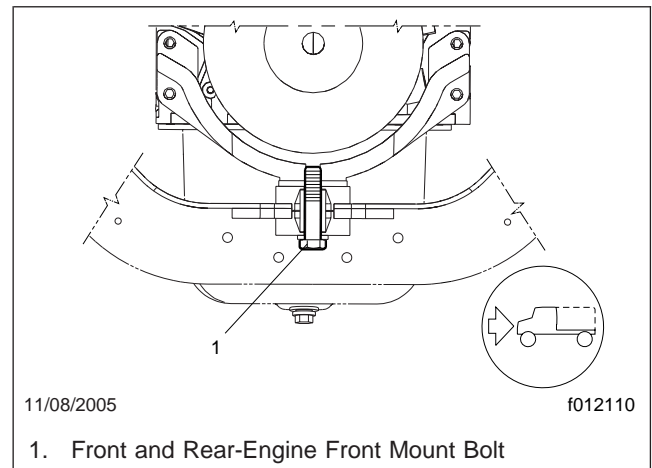

Fig. 2, Front and Rear-Engine Front Mount (ISB chassis built after 2002)

excess moisture, it will be necessary to perform preventative maintenance using the following steps:

1. With the engine turned off, use Pacbrake Synthetic Lube or Synco Super Lube, and spray or coat a sufficient amount on the restrictor air cylinder valve shaft and the attaching locations at each end of the actuation cylinder. See [Fig. 3](#) for the exhaust brake lubrication points.

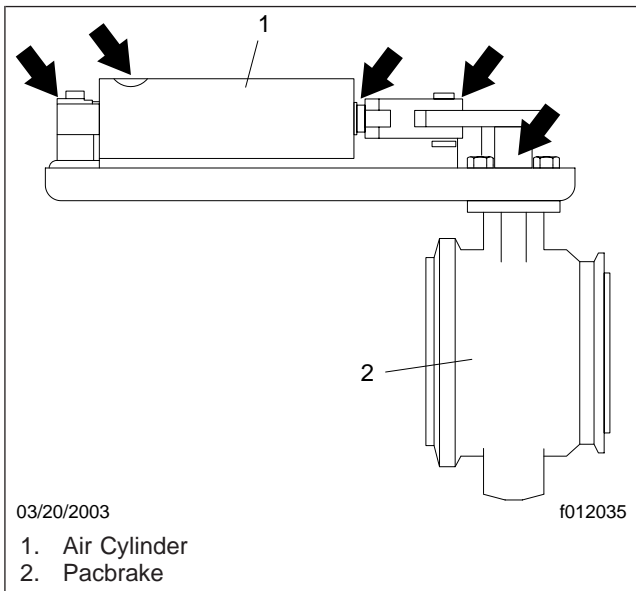

Fig. 3, Pacbrake Exhaust Brake Lube Point Locations

2. Using your hands or a pair of pliers, slide the valve several times to distribute the lubricant down the shaft and the attaching locations.

NOTE: Operation of the Pacbrake could be affected by starting the engine and idling for short periods of time. During a cold engine start-up, moisture occurs in the engine and the exhaust system that creates a corrosion hazard. The brake housing may trap water in the valve shaft bore causing corrosion, resulting in an improper or non-functioning brake. If it is necessary to periodically start the engine, reach normal operating temperatures before shutting down the engine.

Title of Maintenance Operation (MOP)	MOP Number
Air Cleaner Inspecting and Replacing	09-01
Charge Air Cooler Inspecting and Cleaning	09-02

09–01 Air Cleaner Inspecting and Replacing

Inspect the air cleaner for holes or tears at the recommended interval. If the air cleaner is damaged, replace it. See **Group 09** of the *Recreational Vehicle Chassis Workshop Manual* for removal and installation procedures, or take the vehicle to an authorized Freightliner dealer. A typical air cleaner mounting is shown in **Fig. 1**.

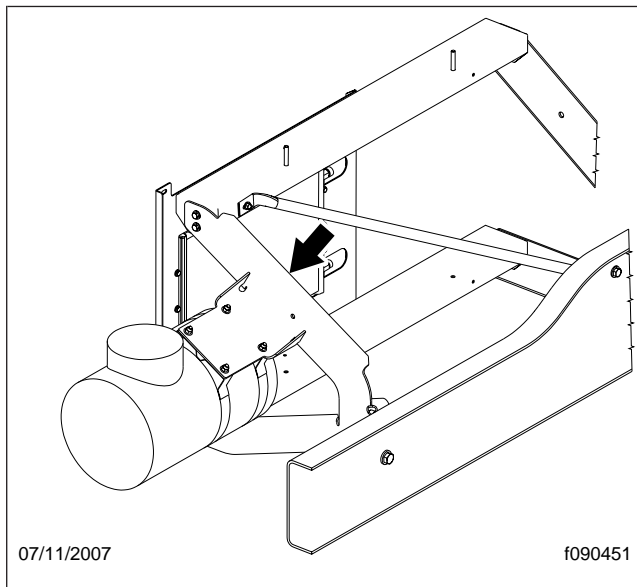

Fig. 1, Air Cleaner Mounting

Engine damage can occur if the air intake system is not properly maintained. Use the air intake restriction indicator to check for air intake system damage or leaks. See **Fig. 2**. Make sure the engine is off and note the existing reading on the indicator. Start the engine and take a short test drive. Check the indicator again and note the level of restriction on the indicator. A decrease from the previous level of restriction or a very low air restriction indicator reading (0 to 4 inH₂O) could indicate an air intake system problem such as a damaged air filter, loose or disconnected air intake piping, or a disconnected or damaged air restriction indicator.

Replace the air cleaner at the recommended interval, or when filter restriction reaches 25 inH₂O. See the *Recreational Vehicle Chassis Operator's Manual* for specific restriction values for your engine. See **Group 09** of the *Recreational Vehicle Chassis Work-*

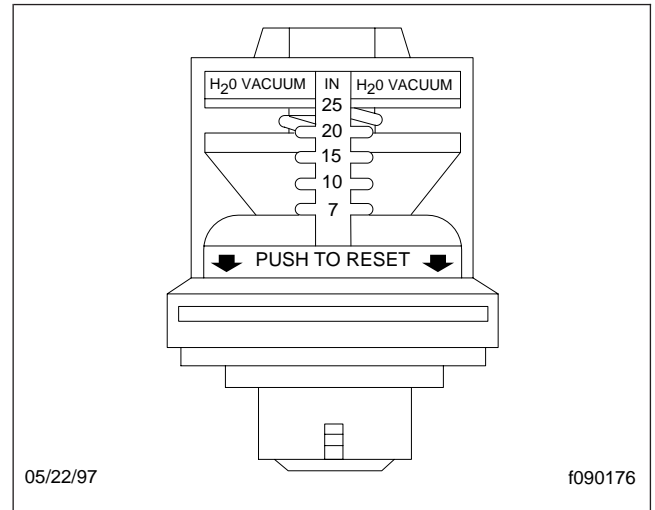

Fig. 2, Air Restriction Indicator

shop Manual for removal and installation procedures, or take the vehicle to an authorized Freightliner dealer.

09–02 Charge Air Cooler Inspecting and Cleaning

Inspect the charge air cooler for clogging or damage and clean and/or repair it if necessary.

Title of Maintenance Operation (MOP)	MOP Number
Alternator, Battery, and Starter Checking.....	15-01

15–01 Alternator, Battery, and Starter Checking

1. Check the tightness of the alternator bracket fasteners and alternator mounting fasteners; tighten the fasteners as needed. For torque values, see **Group 15** of the *Recreational Vehicle Chassis Workshop Manual*, or take the vehicle to an authorized Freightliner dealer.
2. Check that all electrical connections at the alternator and starter are clean. Clean and tighten all charging system electrical connections as needed. Spray each electrical connection at the alternator and starter with dielectric red enamel. See **Table 1**.
3. Check the alternator wiring for missing insulation, kinks, and heat damage. Replace or repair as needed.



WARNING

Batteries generate explosive gas as a by-product of their chemical process. Do not smoke when working around batteries. Put out all flames and remove any source of sparks or intense heat in the vicinity of the battery compartment. Make sure the battery compartment has been completely vented before disconnecting or connecting the battery cables.

Battery acid is extremely harmful if splashed in the eyes or on the skin. Always wear a face shield and protective clothing when working around batteries.

4. Inspect the battery cables for wear, and replace as needed. Clean the cable connector terminals with a wire brush. See **Group 54** of the *Recreational Vehicle Chassis Workshop Manual* for troubleshooting instructions, and for adjustment, repair, or replacement instructions, or take the vehicle to an authorized Freightliner dealer.
 - 4.1 Clean and tighten the battery ground cable, terminal, and clamps.
 - 4.2 Inspect the retainer assembly (or battery hold-downs) and the battery box. Replace worn or damaged parts. Remove any corrosion with a wire brush, and wash with a weak solution of baking soda and water.

Rinse with clean water, and dry. Paint the retainer assembly, if needed, to prevent rusting.

- 4.3 Check that foreign objects, such as stones, bolts, and nuts are removed from the battery box.
- 4.4 After cleaning, connect the cables to the batteries, and tighten them to the torque specifications listed on the battery, generally 10 to 15 lbf-ft (14 to 20 N-m).
- 4.5 Coat the battery terminals with dielectric grease. See **Table 1**.

Approved Dielectric Protectants	
Protectant Material	Approved Brand
Dielectric Grease	Lubriplate FLP DS-ES
Dielectric Red Enamel Spray-On Application	3M 1602 IVI-Spray Sealer
	Spray-On B-6-665
Dielectric Red Enamel Brush-On Application	Gyptal 1201EW-Low VOC, Red; order at www.glyptal.com or 1-800-GLP-1201

Table 1, Approved Dielectric Protectants

5. Check the terminals on the battery shut-off switch and the starter relay. Make sure that the terminal connections are clean and tight. Coat the terminal connections with dielectric red enamel after cleaning; see **Table 1**.

Title of Maintenance Operation (MOP)	MOP Number
Coolant Replacing	20-03
Radiator Cap Checking	20-01
Radiator Inspecting and Cleaning	20-02

20-01 Radiator Cap Checking

WARNING

Do not remove or loosen the radiator cap until the engine and cooling system have completely cooled. Use extreme care when removing the cap. A sudden release of pressure from removing the cap prior to the system cooling can result in a surge of scalding coolant that could cause serious personal injury.

The radiator cap is the most ignored part in the cooling system. If it is suspect, replace it. An inspection means checking the cap with a pressure tester. A radiator cap in good condition will not open below 9 psi (62 kPa). A visual check is also in order: look for signs of deterioration of the inner gasket. Also look for cracks or breaks in the spring retainer in the cap and for corrosion or deposits on the spring itself. If the spring is not in perfect condition, it has probably lost tension; replace it. See [Fig. 1](#).

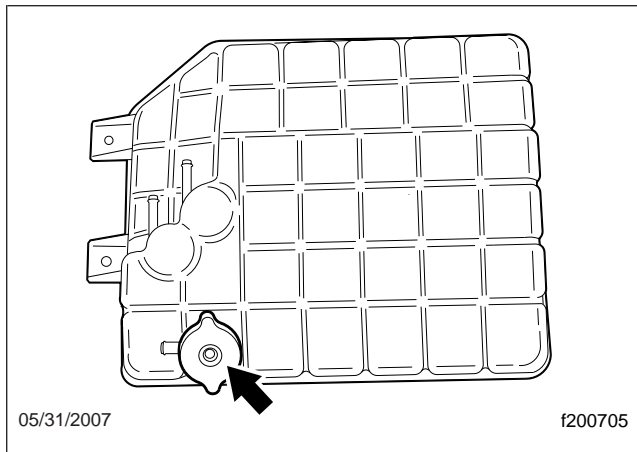

Fig. 1, Surge Tank Coolant Fill Cap

20-02 Radiator Inspecting and Cleaning

Inspect the radiator for clogging or damage and clean and/or repair it if necessary.

20-03 Coolant Replacing

At the intervals specified in the maintenance schedule, or whenever the coolant becomes dirty, flush and refill the cooling system.

NOTE: The coolant replacement interval is increased to 100,000 miles (161 000 km) or 60 months, whichever comes first. For this interval to apply, you must check and, if necessary, recharge the SCA (supplemental coolant additive) levels and the freeze point every 25,000 miles (40 000 km) or 6 months, whichever comes first. See the *Cummins Operation and Maintenance Manual* for further information.

WARNING

Do not remove or loosen the radiator cap until the engine and cooling system have completely cooled. Use extreme care when removing the cap. A sudden release of pressure from removing the cap prior to the system cooling can result in a surge of scalding coolant that could cause serious personal injury.

1. Drain the cooling system, as follows.
 - 1.1 When the engine is cool, remove the radiator cap.

Turn the cap slowly counterclockwise until it reaches a "stop." Do not press down while turning the cap. Wait until any remaining pressure (indicated by a hissing sound) is relieved, then press down on the cap and continue turning it counterclockwise.
 - 1.2 When the cap is removed, run the engine until the upper radiator hose is hot—this shows that the thermostat is open and the coolant is flowing through the system.

WARNING

Use extreme care when draining coolant that is very warm. It may still be hot enough to cause serious personal injury by scalding.

- 1.3 Stop the engine. Remove the lower radiator hose to drain the coolant. Drainage may be speeded by removing the plug in the bottom of the water inlet.

2. Flush the cooling system, as follows.



CAUTION

During filling, air must be vented from the engine coolant passages. Any air trapped in the system can cause severe engine damage.

- 2.1 Connect the lower radiator hose and install the plug in the bottom of the water inlet.
- 2.2 Open the engine venting petcock.
- 2.3 Add water to the surge tank until the system is filled.
- 2.4 Start the engine. Run it at low idle for 10 seconds, then at high idle for 1 minute. Return to low idle.
- 2.5 Close the lower petcock when a steady stream of water is flowing from it. Don't let more than 1.5 quarts (1.4 L) of water escape.
- 2.6 Close the upper petcock when a steady stream of water is flowing from it. Don't let more than 1.5 quarts (1.4 L) of water escape.
- 2.7 Repeat several times until the drained liquid is nearly colorless.
- 2.8 Completely drain the system, then close the radiator and block the drain valves.
- 2.9 Disconnect all hoses from the surge tank. Remove the tank and pour out any fluid. Scrub and clean the inside of the surge tank with soap and water. Flush it with clean water, then drain it. Install the surge tank and hoses.

IMPORTANT: On vehicles with EPA07-compliant engines, the coolant capacity varies depending on the engine and accessory installation. After servicing the cooling system, always verify that the coolant level is between the MIN and MAX lines on the surge tank.

3. Fill the cooling system, as follows.

- 3.1 Slowly add a 50/50 mixture of antifreeze and water to the surge tank until the system is filled. Install the coolant fill cap.

3.2 Start the engine and run it at low idle for 10 seconds; then at high idle for 1 minute. Return to low idle.

3.3 Run the engine, with the radiator cap removed, until the upper radiator hose is hot. With the engine idling, add coolant to the radiator until it is between the MIN and MAX lines on the surge tank. Install the radiator cap.

Title of Maintenance Operation (MOP)	MOP Number
Allison MD/MH Series Transmission Fluid Level Checking	26-02
Allison MD/MH Series Transmission Fluid and Filter Changing (internal/external filter)	26-03
Transmission Breather Checking	26-01

26–01 Transmission Breather Checking

Transmission housing breathers must remain clear. A plugged breather could result in pressure build-up, which could cause lubricant leakage.

If the breather is plugged, clean or replace it. See [Fig. 1](#). Check more often if the vehicle is operating under very dusty conditions.

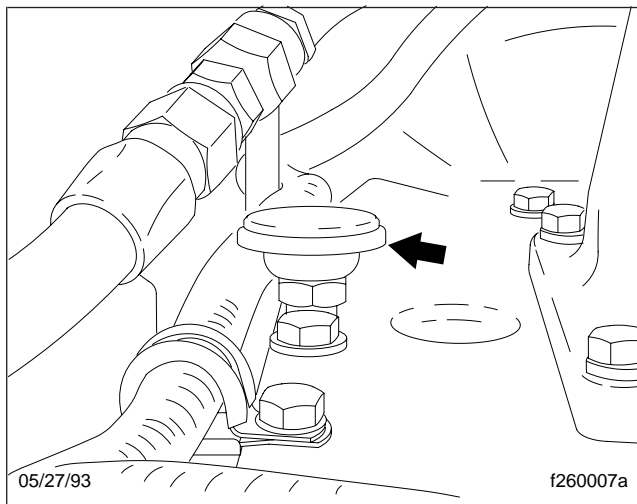

Fig. 1, Transmission Breather

26–02 Allison MD/MH Series Transmission Fluid Level Checking

Cold Check

IMPORTANT: The purpose of the cold check is only to determine if the transmission has enough fluid to be safely operated until a hot check can be made.

1. A cold check may be made when the sump temperature is 60° to 104°F (15° to 40°C).
2. Run the engine for at least one minute to clear the fluid system of air.
3. With the engine running, wipe the dipstick clean and check the fluid level. Any level within the COLD RUN (lower) band is satisfactory for operating the vehicle. See [Fig. 2](#). If the level is not

within the COLD RUN band, add or drain fluid until it reaches the middle of the COLD RUN band.

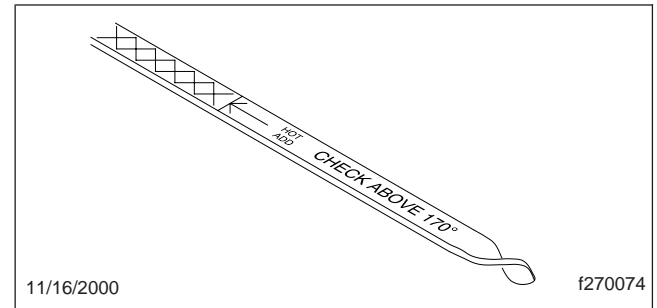

Fig. 2, Transmission Dipstick

4. Perform a hot check at the first opportunity after normal operating temperature, 160° to 200°F (71° to 93°C), is reached.

Hot Check

1. Operate the transmission in a Drive (D) range until normal operating temperature, 160° to 200°F (71° to 93°C), is reached.

NOTE: The fluid must be warm to ensure an accurate check. The fluid level rises as temperature increases.

2. Park the vehicle. Shift to Neutral (N) and apply the parking brake. Let the engine run at idle.
3. Wipe the dipstick clean and check the fluid level. A safe operating level is any level within the HOT RUN (upper) band on the dipstick. See [Fig. 2](#).
4. If the fluid is not within this range, add or drain fluid as needed to bring the level to the top of the HOT RUN band. See [Table 1](#) for approved transmission lubricants. See [Table 2](#) for lubricant capacities.

Lubricant Type	Temperature: °F (°C)
TranSynd Synthetic ATF	-25 to +120 (-32 to +48)

Table 1, Approved Automatic Transmission Lubricants

Model	Refill Capacity*: qt (L)
1000, 2000, and 2000 MH	16.0 (15.1)

Model	Refill Capacity*: qt (L)
3000 MH† and 4000 MH	17.5 (16.5)

* Quantities listed are approximate. Add the recommended amount of fluid as listed under refill capacity, then perform a "hot check" and add fluid as needed. Do not overfill.

† Some Allison 3000 MH transmissions have a deeper oil sump than other models. These models require 3 additional quarts (2.8 L) of ATF.

Table 2, Automatic Transmission Lubricant Capacities

26–03 Allison MD/MH Series Transmission Fluid and Filter Changing (internal/ external filter)

IMPORTANT: For oil and filter change intervals, see the applicable Allison Operator's Manual.

NOTE: All recreational vehicle chassis manufactured since January 1, 2004 use TranSynd synthetic automatic transmission fluid (ATF).

IMPORTANT: For vehicles manufactured before January 1, 2004, extended oil and filter change intervals (as advertised by Allison beginning in 2002) do not apply to Allison transmissions in Freightliner-chassis vehicles. Allison transmissions are received partially filled with TranSynd synthetic automatic transmission fluid (ATF). They are then topped-off with a non-TranSynd ATF.

Allison's recommended extended oil and filter change intervals for TranSynd-only or for a "mixture" of TranSynd and non-TranSynd do not apply. To qualify for the "mixture" intervals, the transmission must be drained as in a standard fluid change and then filled with TranSynd. See the applicable Allison Operator's Manual for specific information.

For 1000/2000/2400 series transmissions with non-TranSynd ATF and for the 2000 MH transmission (in which *only* TranSynd is used), change oil and filters at 50,000 miles (80 000 km) or 24 months, whichever comes first.

For MD/HD and 3000/4000 MH series transmissions, change oil and filters at 25,000 miles (40

000 km) or 12 months, whichever comes first. See the applicable Allison Operator's Manual for specific information.

1. Park the vehicle on a level surface and apply the parking brakes.
2. Run the engine until the transmission fluid reaches the operating temperature of 160 to 200°F (71 to 93°C). Shift the transmission to Neutral (N) and shut down the engine.

CAUTION

To prevent dirt from entering the transmission, use only clean containers and fillers for the transmission fluid. Do not use fillers or containers that have been used for water or antifreeze. Dirt, water, or antifreeze could damage the transmission.

3. Clean the area around the drain plug. See [Fig. 3](#) and [Fig. 4](#). While the transmission fluid is warm, remove the drain plug, and drain the fluid.

IMPORTANT: Examine the used transmission fluid for dirt, coolant or water, and metal particles. If any of these contaminants are present, a problem within the transmission system may exist.

4. Remove the bolts from each filter cover at the bottom of the transmission control module. See [Fig. 3](#) and [Fig. 4](#). Remove the filter covers, O-rings, seals, and the two cartridge-type filters.
5. Lightly coat the O-rings with clean transmission fluid. Place the O-rings, seals, and filters on the filter covers. Push each cover assembly into the bottom of the transmission to seat the seals. Install and tighten the bolts 38 to 45 lbf-ft (52 to 61 N·m). Install and tighten the drain plug 18 to 24 lbf-ft (24 to 33 N·m).
6. Clean the area around the fill tube and remove the dipstick. Using a clean funnel in the fill tube, add transmission fluid. See [Table 1](#) for approved transmission lubricants. See [Table 2](#) for lubricant capacities.
7. Check and adjust the fluid level using the procedures under "Allison MD/MH Series Transmission Fluid Level Checking."

NOTE: For additional maintenance procedures, see the applicable Allison Operator's Manual.

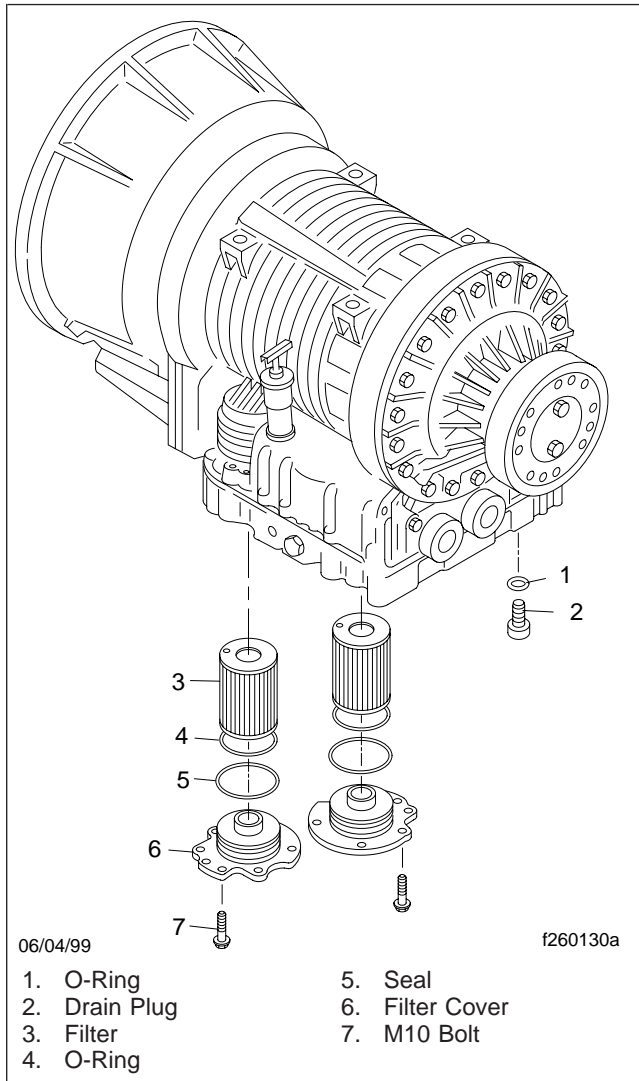

Fig. 3, Allison 3000 MH Transmission Filters

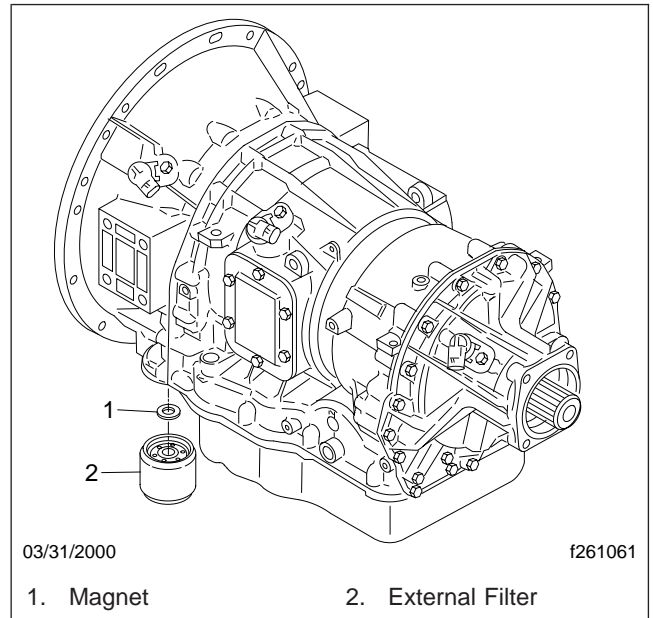

Fig. 4, 1000/2000/2400 MH Series Transmission External Filter

Title of Maintenance Operation (MOP)	MOP Number
Throttle Pedal Pivot Pin Lubricating.	30-01

30-01 Throttle Pedal Pivot Pin Lubricating

Using a silicone spray, lubricate the throttle pedal pivot pins.

Title of Maintenance Operation (MOP)

MOP Number

Frame Fastener Torque Checking 31-01

31–01 Frame Fastener Torque Checking

Because of "bedding in" (or seating), the frame fasteners must be torqued at the recommended intervals. These intervals apply to new vehicles, and to frame fasteners that have been removed and installed.

 **CAUTION**

Make sure frame fasteners are properly tightened. Continued vehicle operation with loose fasteners could result in bracket or frame damage.

Typical frame fastener applications include suspension brackets, fuel tank, exhaust and engine supports, and frame crossmembers and gussets.

NOTE: This operation is not intended to be a bolt-by-bolt check of the entire chassis. Do a hand check of the typical frame fasteners. If any fasteners are found loose, tighten them to the correct torque value.

See **Group 00** of the *Recreational Vehicle Chassis Workshop Manual* for additional information on fasteners and torque values, or take the vehicle to an authorized Freightliner dealer.

Title of Maintenance Operation (MOP)	MOP Number
Neway Suspension Fastener Torque Checking	32-01
Neway Suspension Height Control Valve Checking	32-02
Neway Suspension Inspecting	32-03
Neway Suspension Lubricating	32-04
Suspension Inspecting (front-engine diesel chassis)	32-06
Suspension U-Bolt Torque Checking (front-engine diesel chassis)	32-07
ZF IFS Lubricating	32-05

32-01 Neway Suspension Fastener Torque Checking

 **WARNING**

Inspect the suspension fasteners. Failure to perform inspections could result in separation of worn suspension components and loss of vehicle control, possibly causing personal injury or death, or property damage.

1. Chock the front or the rear tires. Working at the front of the vehicle or at the rear of the vehicle, raise the vehicle so that the tires just clear the ground and the suspension is fully extended. Place safety stands under the vehicle frame.
2. Check the suspension fasteners. See [Table 1](#) for correct fastener torques.

Suspension Torque Specifications (lubricated threads)		
Description	Size	Torque: lbf-ft (N·m)
Shock Absorber Mount Locknut	3/4-16	110 to 150 (149 to 203)
Air Spring Upper Mounting Plate Locknut	3/4-16	31 to 42 (42 to 57)
Air Spring Upper Mounting Plate Capscrew	1/2-13	31 to 42 (42 to 57)
Air Spring Lower Mounting Plate Capscrew	1/2-13	31 to 42 (42 to 57)
Transverse Beam Bushing Locknuts	1-1/4-12	600 to 700 (814 to 950)
Equalizing Beam Center Bushing Locknut	3/4-16	150 to 200 (203 to 271)
Equalizing Beam Front Bushing Locknut	1-1/8-12	600 to 700 (814 to 950)
	1-1/4-12	
Control Rod Ball Stud Locknut	1-1/8-12	550 to 650 (746 to 880)
Control and Torque Rod Mounting Locknuts	5/8-18	110 to 150 (149 to 203)

Table 1, Suspension Torque Specifications (lubricated threads)

3. Check the torque of the rear axle U-bolts.

In a diagonal pattern, tighten all 5/8-18 U-bolt nuts 205 lbf-ft (278 N·m); tighten all 3/4-16 U-bolt nuts 300 lbf-ft (407 N·m); and tighten all 7/8-14 U-bolt nuts 460 lbf-ft (624 N·m).

 **CAUTION**

Failure to retorque the U-bolt nuts could result in spring breakage and abnormal tire wear.

4. Remove the safety stands and lower the vehicle to the ground.

32-02 Neway Suspension Height Control Valve Checking

 **WARNING**

Inspect the height control components and check their operation. Failure to perform these inspections and checks could result in separation of worn suspension components and loss of vehicle control, possibly causing personal injury or death, or property damage.

1. Park the vehicle on a level surface. Apply the parking brakes and chock the tires to prevent the vehicle from moving.
2. Inspect the front and rear suspensions for any signs of damage, loose components, wear, or cracks. Replace any damaged components to prevent failure or equipment breakdown.
3. Inspect all bolts and nuts at the pivot axle connections to assure that they are properly torqued. Check all other nuts and bolts for proper torque. See [Group 00](#) of this manual for proper torque specifications.
4. Check the air pressure gauge to confirm that there is in excess of 65 psi (448 kPa) in the air system, and inspect the air springs for sufficient and equal firmness.

NOTE: Height control valves control all front and rear suspension air springs. Check for air leaks by applying a soapy solution. Then, check for bubbles at all air connections and fittings.

5. Check the ride height of the air suspension by measuring the distance from the center of the

lower shock bolt to the bottom of the frame rail. See **Fig. 1**. If ride height is incorrect, adjust the air suspension.

32-03 Neway Suspension Inspecting

WARNING

Inspect the components and check their operation as described below. Failure to perform these inspections and checks could result in separation of worn suspension components and loss of vehicle control, possibly causing personal injury or death, or property damage.

1. Chock the front or the rear tires. Working at the front of the vehicle or at the rear of the vehicle, raise the vehicle so that the tires just clear the ground and the suspension is fully extended. Place safety stands under the vehicle frame.
2. Squeeze all air springs to check for complete deflation. It may take ten minutes for the pressure to bleed down from the air spring. See **Fig. 2**. If any air springs remain partially or fully inflated, see **Group 32** of the *Recreational Vehicle Chassis Workshop Manual*, or take the vehicle to an authorized Freightliner dealer. Inspect the air springs for cracks, tears, or other damage.
3. Inspect each air spring for wear at the pedestal connection. Inspect for leaks at the upper and lower pedestal connections using a soapy solution. Replace any worn air springs; for instructions, see **Group 32** of the *Recreational Vehicle Chassis Workshop Manual*, or take the vehicle to an authorized Freightliner dealer.
4. Inspect the bolts and nuts at the pivot connections, the transverse beam connections, and the axle connections to ensure they are tightened to the correct torque specification.

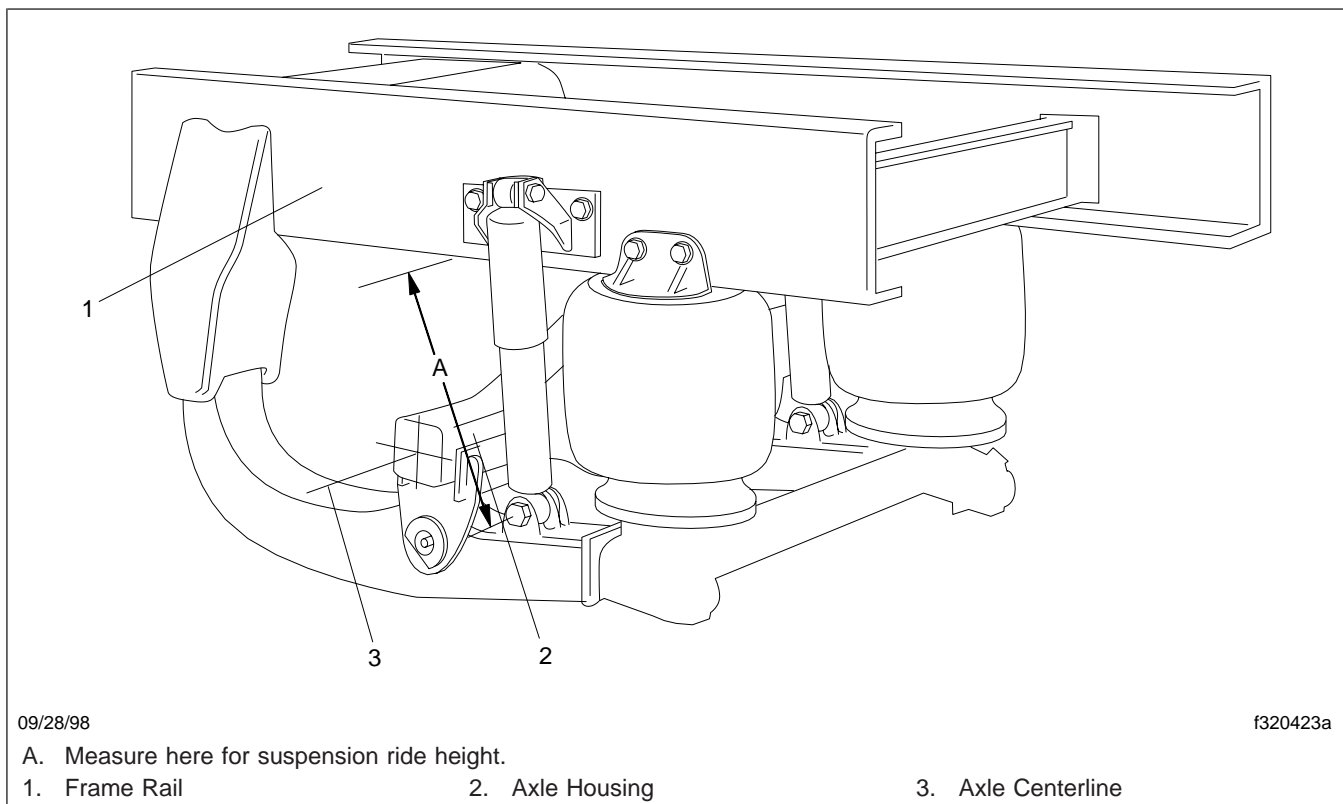

Fig. 1, Ride Height Inspection (typical Neway suspension shown)

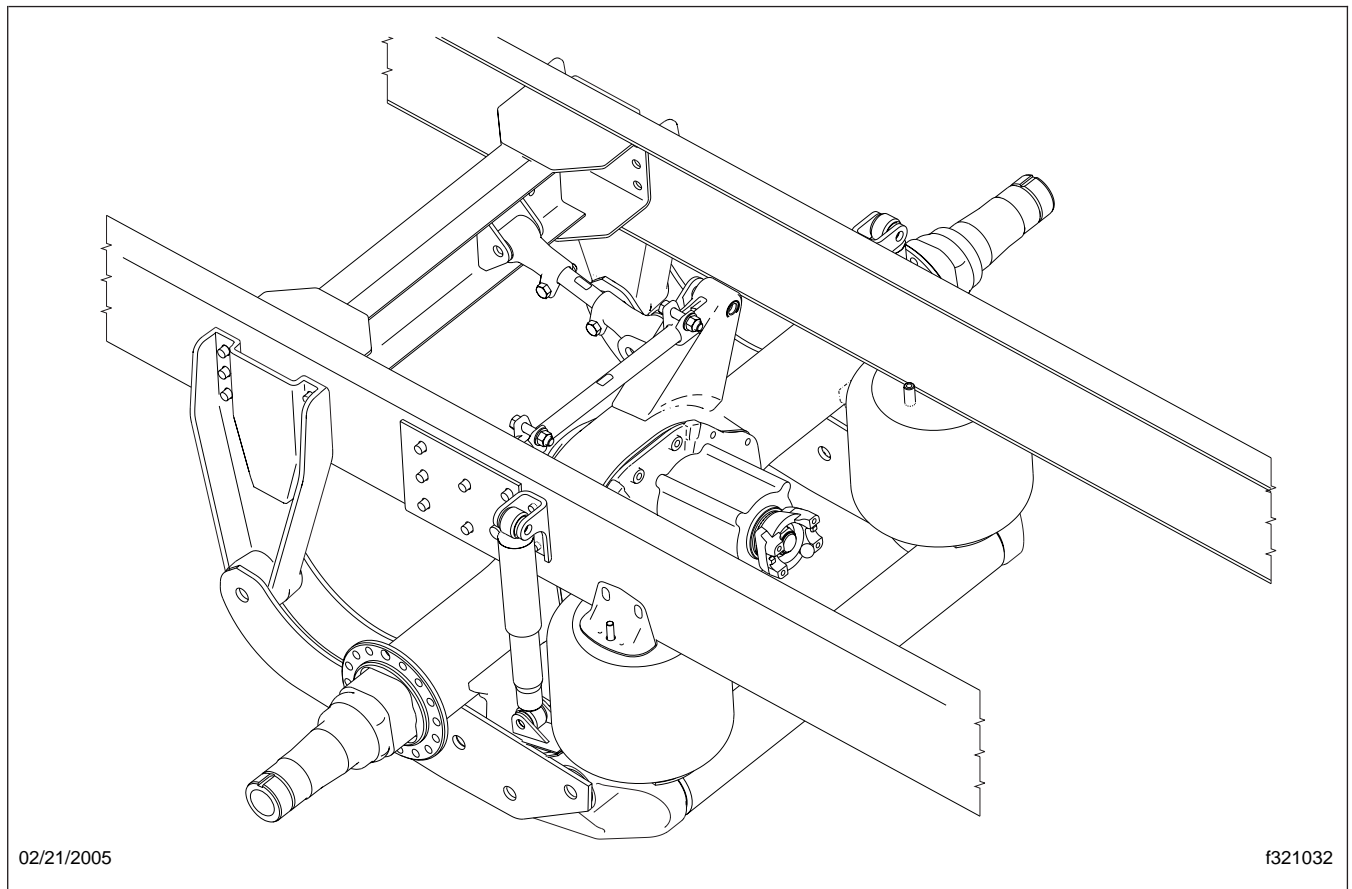

Fig. 2, Holland Neway ADL 120/123 Suspension

5. Check all of the other suspension components for any sign of damage, looseness, wear, or cracks. Replace worn or damaged parts. See **Group 32** of the *Recreational Vehicle Chassis Workshop Manual*, or take the vehicle to an authorized Freightliner dealer.
6. Inspect for cracked welds. If cracks are found, contact Neway immediately for further instructions.
7. Inspect the torque rod and track bar pivot bushings for excessive wear. Replace worn or damaged bushings. See **Group 32** of the *Recreational Vehicle Chassis Workshop Manual*, or take the vehicle to an authorized Freightliner dealer.
8. Move the axle up and down while checking for signs of looseness due to worn parts at the front pivot connections. Replace any worn parts by following the procedures in **Group 32** of the *Recreational Vehicle Chassis Workshop Manual*, or take the vehicle to an authorized Freightliner dealer.
9. Check for leaks on the height control valves by applying a soapy solution, then, watching for bubbles at all air connections and fittings.
10. Inspect the shock absorbers for oil leaks and worn rubber bushings. Replace the shock absorbers and/or rubber bushings if wear or damage is noted. For instructions, see **Group 32** of the *Recreational Vehicle Chassis Workshop Manual*, or take the vehicle to an authorized Freightliner dealer.
11. Remove the safety stands and lower the vehicle to the ground. Run the engine until air pressure of at least 100 psi (689 kPa) is maintained throughout the system.

IMPORTANT: Repeat this check at both ends of the vehicle.

- Check that all air springs are inflated. If the air springs do not inflate, see **Group 32** of the *Recreational Vehicle Chassis Workshop Manual* for possible causes and corrections, or take the vehicle to an authorized Freightliner dealer.

32-04 Neway Suspension Lubricating

When lubricating the front suspension (Neway IFS-114) post/control arm bearings, wipe the lube fittings clean, and slowly feed lithium-based wheel bearing grease into each bearing location.

Hold a high-pressure grease gun on each front suspension grease fitting until fresh grease appears. See **Fig. 3**. This will ensure that all of the old contaminated grease has been forced out. Lubricate the post/control arm bearings at indicated maintenance intervals.

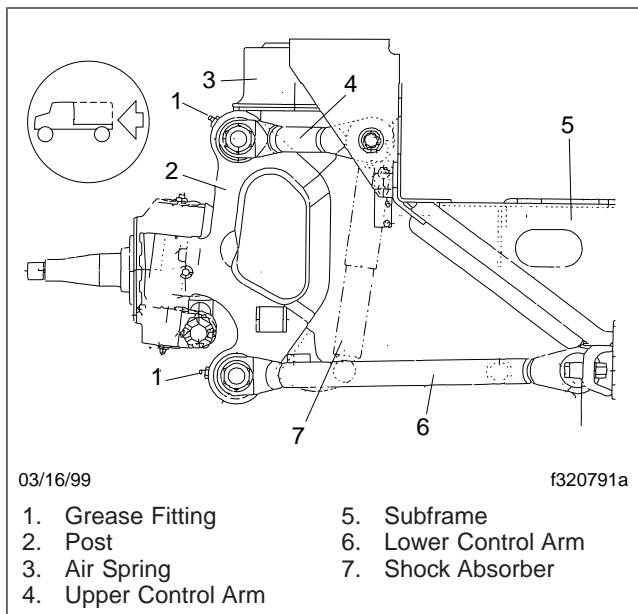

Fig. 3, Neway IFS-114 Grease Fittings

32-05 ZF IFS Lubricating

IMPORTANT: Do not raise the vehicle by placing a jack under the control arm(s). The weight

of the vehicle could damage the control arms and cause alignment issues.

- Chock the rear tires and apply the parking brake. Raise the front of the vehicle with a jack so the tires just clear the ground and the suspension is fully extended. Place safety stands under the vehicle frame.

WARNING

Never work around or under a vehicle that is supported only by a jack. Always support the vehicle with safety stands. Jacks can slip, causing the vehicle to fall, which could result in serious injury or death.

- Remove the wheel hub. See **Group 33** of the *Recreational Vehicle Chassis Workshop Manual* for wheel bearing service procedures, or take the vehicle to an authorized Freightliner dealer.
- Lubricate the steering knuckle/control arm at indicated maintenance intervals. Use only an NLGI Grade 2 lithium-based grease, multipurpose grease, or mineral oil on the lubricating points. See **Fig. 4** and **Fig. 5**.

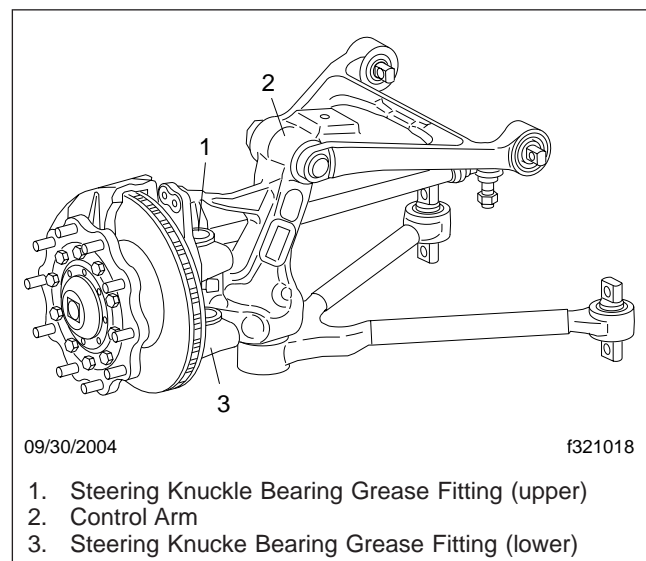

Fig. 4, Pressure Grease Fitting Positions, RL-75E

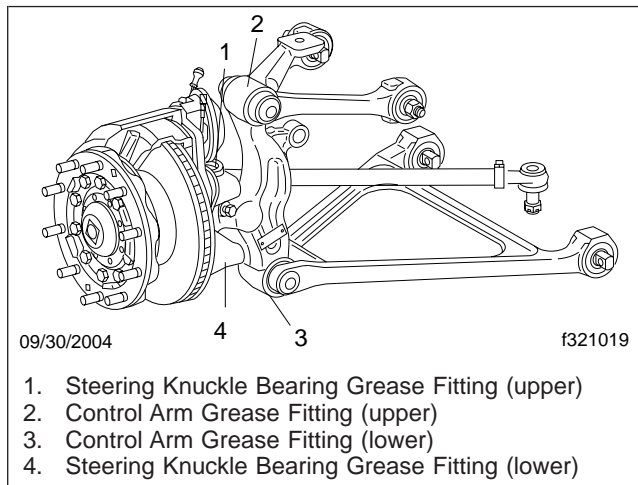

Fig. 5, Pressure Grease Fitting Positions, RL-75EM

32-06 Suspension Inspecting (front-engine diesel chassis)

Freightliner Spring Front and Rear Suspension Spring Assemblies Inspection

Inspect the front and rear suspension spring assemblies for pitted, cracked, broken, or abnormally bent leaves and extreme rust. If any of these conditions exist, replace the spring assembly. See **Group 32** of the *Recreational Vehicle Chassis Workshop Manual* for instructions, or take the vehicle to an authorized Freightliner dealer.

WARNING

Do not replace individual leaves of a damaged leaf spring assembly; replace the complete spring assembly. Visible damage (cracks or breaks) to one leaf causes hidden damage to other leaves. Replacement of only the visibly damaged part(s) is no assurance that the spring is safe. On front spring assemblies, if cracks or breaks exist in the

two top leaves, a loss of vehicle control could occur. Failure to replace a damaged spring assembly could cause an accident resulting in property damage, serious personal injury, or death.

IMPORTANT: On multi-leaf suspensions, closely inspect each component of the leaf spring assemblies, including the brackets, U-bolts, and related parts.

60-Inch Taper-Leaf Spring Component Check

No lubrication is required on the 60-inch taper-leaf spring front and rear suspension.

Inspect the rear shackle brackets for bushing wear or cracks.

Inspect the stabilizer bar, if present, for irregular bushing wear or cracks in the brackets. Check the rubber helper spring, if present, for cracks.

32-07 Suspension U-Bolt Torque Checking (front-engine diesel chassis)

Check the U-bolt torque of both the front and rear axles where applicable.

CAUTION

Failure to retorque the U-bolt nuts could result in spring breakage and abnormal tire wear.

1. Park the vehicle on a flat surface, apply the parking brake, and chock the tires.
2. Check the U-bolt torque in a diagonal pattern. Set a click-type torque wrench to the highest torque value for the fastener being checked. See **Table 2** for U-bolt torque specifications. Turn the wrench in a clockwise motion (looking up) until the torque wrench clicks.
3. Remove the chocks.

U-Bolt Torque Values		
Description	Size	Torque: lbf·ft (N·m)
Spring Assembly U-Bolt High Nuts*	5/8-18	Stage 1: Hand tighten Stage 2: 60 (81) Stage 3: 200 (271) Stage 4: 180 to 230 (245 to 313)
	3/4-16	Stage 1: Hand tighten Stage 2: 60 (81) Stage 3: 200 (271) Stage 4: 270 to 330 (367 to 449)

* Tighten in the sequence shown in Fig. 6.

Table 2, U-Bolt Torque Values

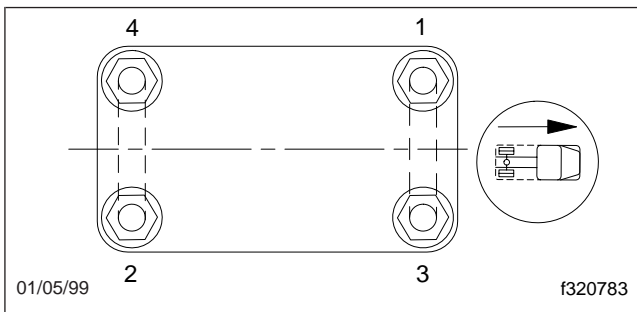

Fig. 6, Tightening Sequence for U-Bolt High Nuts

Title of Maintenance Operation (MOP)	MOP Number
All-Axle Alignment Checking	33-03
Knuckle Pin Lubricating	33-01
Oil-Filled Hubs Oil Changing	33-06
Oil-Filled Hubs Oil Level Checking	33-05
Tie-Rod End Lubricating and Inspecting	33-02
Wheel Bearing Removal, Cleaning, Checking, Repacking, and Adjusting	33-04

33-01 Knuckle Pin Lubricating

Hold a high-pressure grease gun on each fitting until fresh grease appears. See **Fig. 1** or **Fig. 2**. This will ensure that all of the old contaminated grease has been forced out.

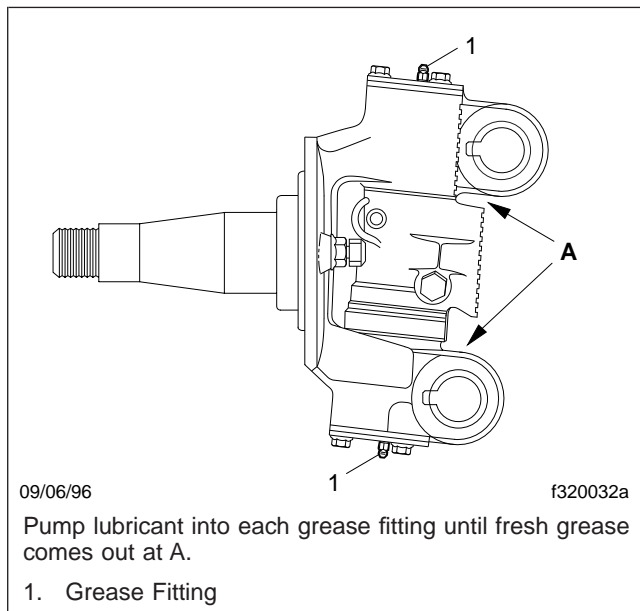

Fig. 1, Meritor Axle Grease Fittings

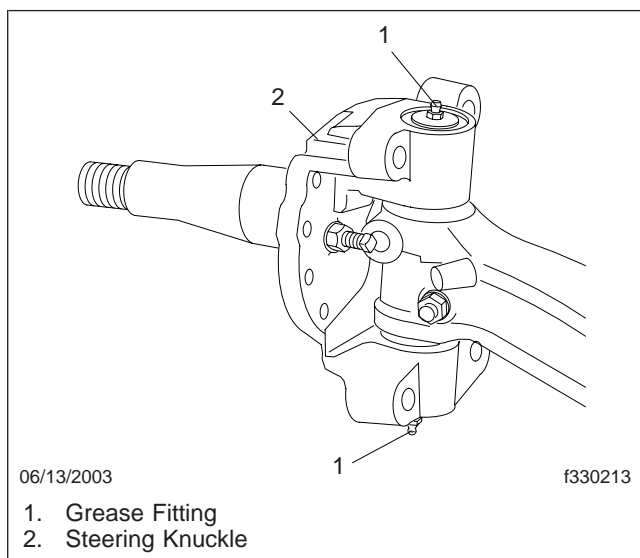

Fig. 2, ABP Axle Grease Fittings

When lubricating Meritor axle knuckle pin bushings or Alliance Brand Product (ABP) axle needle bearings at the initial maintenance (IM) interval, first wipe the lube fittings clean. Then, slowly feed (for Meritor axles) multipurpose chassis grease (NLGI grade 1 or 2) into each bushing area, or (for ABP axles), lithium 12-hydroxy stearate (with molybdenum disulfide) WL grade 2 grease into each needle bearing area, while turning the wheels from extreme right to left, and back again (lock-to-lock). This will eliminate small air pockets and improve grease distribution.

NOTE: The grease seal will accept the grease pressure without damaging the seal, and is designed to have grease pumped out through it during lubrication. Even if grease leaks out around the top or bottom plate, continue pumping until new grease is seen at the seal on the bushing or needle bearing opposite the grease fitting.

When lubricating knuckle pin bushings or needle bearings after the IM maintenance interval, first wipe the lube fittings clean. Then, (for Meritor axles) apply multipurpose chassis grease, or (for ABP axles), lithium 12-hydroxy stearate (with molybdenum disulfide) WL grade 2 grease, until new grease is seen at the grease seal on the bushing or needle bearing opposite the fittings.

33-02 Tie-Rod End Lubricating and Inspecting

IMPORTANT: DOT roadside tie-rod assembly replacement criteria specifies that if tie-rod end-play is 1/8 inch (3 mm) or greater, measured on the road, the vehicle must be taken out of service immediately. If less than 1/8 inch (3 mm), the vehicle does not have to be taken out of service but a major out-of-service inspection and maintenance must be scheduled as soon as possible.

1. Wipe the tie-rod end grease fittings clean, then (for Meritor axles) pump multipurpose chassis grease (NLGI grade 1 or 2), or (for Freightliner axles), lithium 12-hydroxy stearate (with molybdenum disulfide) WL grade 2 grease, to the tie-rod ends until all used grease is forced out and new grease appears at the ball stud neck.

NOTE: Inspect the tie-rod end boots for cracks, wear, or damage. If a boot is cracked, worn, or damaged, replace the tie-rod assembly.

2. Inspect the tie-rod ends, as follows.
 - 2.1 Shake the cross-tube. Movement or looseness between the tapered shaft of the ball and the cross-tube socket members means that the tie-rod end assembly must be replaced.
 - 2.2 The threaded portion of the tie-rod end assembly must be inserted all the way into the cross-tube split for adequate clamping. See Fig. 3. Replace the parts if this cannot be done. For instructions, see the axle manufacturer's service manual.
 - 2.3 Check the tie-rod end nut and clamp nut torques. For Meritor axles, tighten the tie-rod end nut 100 lbf-ft (136 N-m), and tighten the clamp nut 40 to 55 lbf-ft (54 to 75 N-m). For Freightliner axles, see Table 1 for tie-rod end nut torque specifications and Table 2 for tie-rod end clamp nut torque specifications.

Freightliner Axle Tie-Rod End Nut	
Thread	Torque: lbf-ft (N-m)
5/8-16	60 to 115 (81 to 156)
5/8-18	60 to 115 (81 to 156)
3/4-16	90 to 170 (122 to 230)
7/8-14	160 to 300 (217 to 407)

Table 1, Freightliner Axle Tie-Rod End Nut

Freightliner Axle Tie-Rod End Clamp Nut	
Thread	Torque: lbf-ft (N-m)
1/2-13	35 to 45 (47 to 61)
5/8-11	40 to 60 (54 to 81)
5/8-18	50 to 64 (73 to 87)
3/4-10	155 to 175 (210 to 237)

Table 2, Freightliner Axle Tie-Rod End Clamp Nut

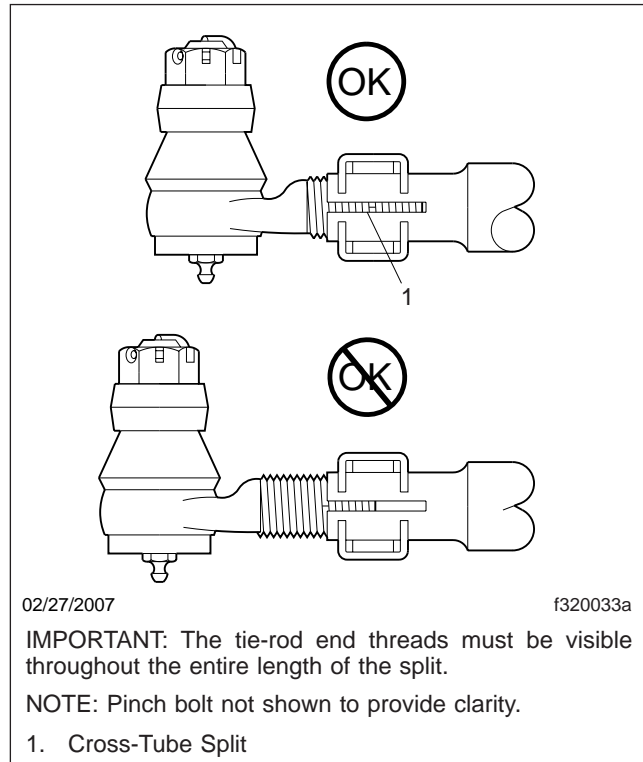

Fig. 3, Tie-Rod End Adjustment

33-03 All-Axle Alignment Checking

NOTE: The final stage manufacturer is responsible for setting the vehicle ride height with air suspension and some vehicle alignments. On full-railed chassis, this includes the final toe-in setting on the front axle. For modular style chassis, both the front axle toe-in and rear axle thrust angle settings are included.

Drive Axle Alignment Checking

Check the axle alignment, parallelism, and thrust angle measurements for the rear axle. Use the applicable procedure and specifications in **Group 35** of the *Recreational Vehicle Chassis Workshop Manual*, or take the vehicle to an authorized Freightliner dealer.

Toe-In Inspection

For vehicle alignment to be accurate, the shop floor must be level in every direction. The turn plates for the front wheels must rotate freely without friction, and the alignment equipment must be calibrated every three months by a qualified technician from the equipment manufacturer. Freightliner dealers must have proof of this calibration history.

1. Apply the parking brakes, and chock the rear tires.
2. Raise the front of the vehicle until the tires clear the ground. Check that the safety stands will support the combined weight of the body, axle, and frame. Place safety stands under the axle.
3. Using spray paint or a piece of chalk, mark the entire center rib of each front tire.
4. Place a scribe or pointed instrument against the marked center rib of each tire, and turn the tires. Hold the scribe firmly in place so that a single straight line is scribed all the way around each front tire.
5. Place a turn-plate or turntable under both front tires. Remove the safety stands from underneath the axle, then lower the vehicle. Remove the lockpins from the gauges; make sure that the tires are pointing straight ahead.

NOTE: If turn-plates or turntables are not available, lower the vehicle. Remove the chocks from the rear tires and release the parking brake. Move the vehicle backward and then forward about six feet (two meters).

6. Place a trammel bar at the rear of the front tires; locate the trammel pointers at spindle height, and adjust the pointers to line up with the scribe lines on the center ribs of the front tires. See [Fig. 4](#). Lock the pointers in place. Check that the scale is set to zero.
7. Place the trammel bar at the front of the tires and adjust the scale end so that the pointers line up with the scribe lines. See [Fig. 5](#) and [Fig. 6](#).
8. Read the toe-in from the scale, and compare it to the toe-in specification in **Group 33** of the *Recreational Vehicle Chassis Workshop Manual*, or take the vehicle to an authorized Freightliner dealer. If corrections are needed, see **Group 33** of the *Recreational Vehicle Chassis Workshop*

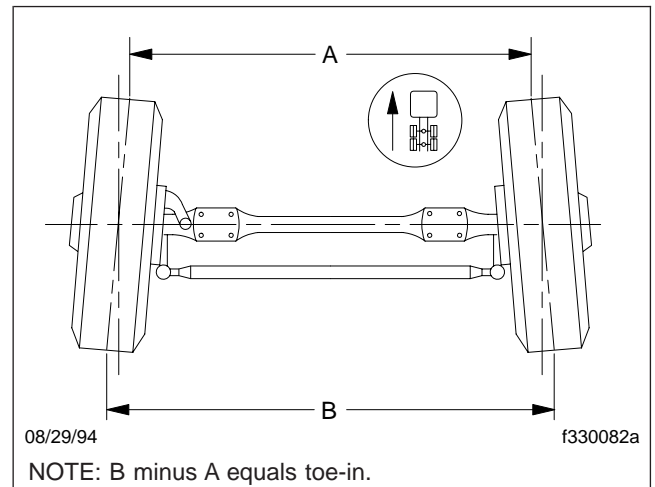

Fig. 4, Wheel Toe-In (overhead view)

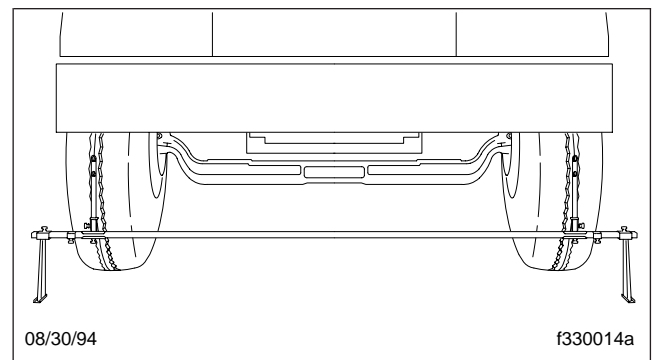

Fig. 5, Trammel Bar Positioning

Manual, or take the vehicle to an authorized Freightliner dealer.

33–04 Wheel Bearing Removal, Cleaning, Checking, Repacking, and Adjusting

See **Group 33** of the *Recreational Vehicle Chassis Workshop Manual* for wheel bearing service procedures, or take the vehicle to an authorized Freightliner dealer.

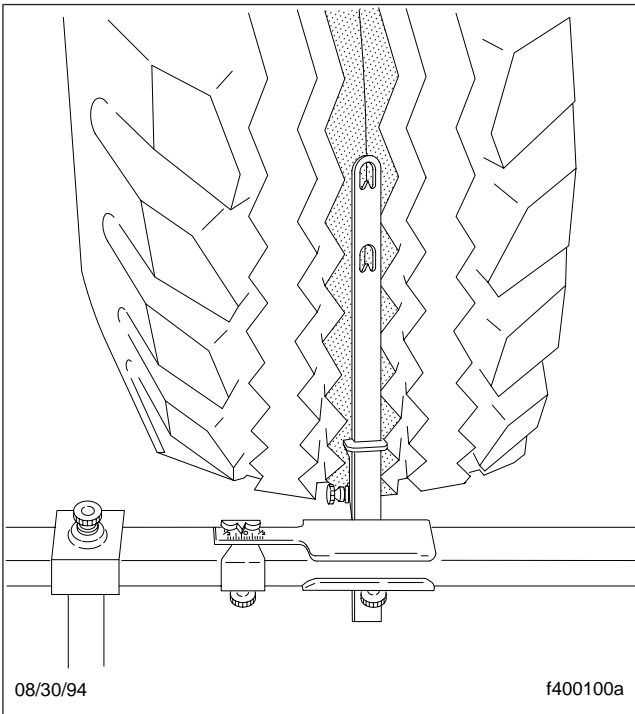

Fig. 6, Setting Trammel Bar Pointers

33-05 Oil-Filled Hubs Oil Level Checking

⚠ WARNING

Be careful not to overfill the hubs. Overfilling may cause oil to be forced out of the hubs and to contaminate the brake linings and other brake components. This could result in loss of vehicle control and lead to personal injury and property damage.

1. With the vehicle on a level surface, rotate the front wheels and allow the oil in the hubs to settle.
2. Chock the tires.

IMPORTANT: The oil level should be at, or no more than 1/4 inch (6 mm) above the level indicators on the hub caps.

3. If necessary, remove the filler caps (in the ends of the hub caps) and add enough oil (80W-90 hypoid gear oil) to bring the oil to the proper level.

4. Rotate the wheels, allow the oil to settle, and check the levels again.
5. Install the filler caps securely.
6. Remove the chocks from the tires.

33-06 Oil-Filled Hubs Oil Changing

⚠ WARNING

Be careful not to overfill the hubs. Overfilling may cause oil to be forced out of the hubs and to contaminate the brake linings and other brake components. This could result in loss of vehicle control and lead to personal injury and property damage.

1. With the vehicle on a level surface, rotate the front wheels so that the front hub drain plugs are positioned downward.
2. Chock the tires.
3. Place suitable containers under the hubs, remove the filler caps (in the ends of the hub caps) and the drain plugs, and allow the hubs to drain completely.
4. Install the drain plugs and tighten securely.
5. Add approximately 1 to 1-1/2 pints (0.5 to 0.7 L) of oil (80W-90 hypoid gear oil) to each hub.
6. Rotate the wheels, allow the oil to settle, and check the levels.

IMPORTANT: Fill the hubs to the level indicators on the hub caps, or to no more than 1/4 inch (6 mm) above the indicators.

7. Install the filler caps securely.
8. Remove the chocks from the tires.

Title of Maintenance Operation (MOP)	MOP Number
Axle Breather Checking	35-03
Axle Lubricant Changing	35-02
Axle Lubricant Checking	35-01

35-01 Axle Lubricant Checking

NOTE: If the vehicle is exposed to water deep enough to cover the hubs, disassemble and inspect them for water damage and/or contamination. See **Group 35** of the *Recreational Vehicle Chassis Workshop Manual* for instructions, or take the vehicle to an authorized Freightliner dealer.

1. Clean the area around the filler plug, and remove the plug.
2. Make sure that the lubricant is level with the bottom of the filler plug hole. See **Fig. 1**.

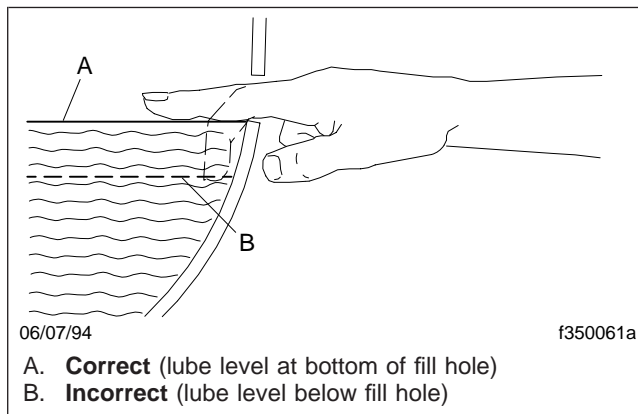

Fig. 1, Axle Lubricant Checking

3. Add S.A.E. 80W-90 multipurpose gear lubricant, or an S.A.E. 75W-90 multipurpose synthetic gear lubricant. Either type of lubricant must meet Military Specification L-2105-D and be suitable for American Petroleum Institute service classification GL-5. Install and tighten the filler plug.
4. Inspect the axle for signs of leakage. If leakage is indicated and the lubricant level is down, have your dealer perform any necessary maintenance.

35-02 Axle Lubricant Changing

Alliance Brand Product (ABP) Axle

1. Remove the filler plug, then the drain plug (in the center bottom of the axle housing), and allow the differential to drain completely.
2. Install the drain plug and tighten it securely.
3. Fill the differential with 80/90 hypoid gear oil through the rear axle fill hole. See **Table 1** for axle lubricant capacities.

NOTE: A normal oil change does not include the hubs. Drain the differential and add 5.8 qt (5.5 L) of SAE 80/90 hypoid gear oil through the rear axle fill hole. The lubricant level should be at the bottom of the fill hole.

IMPORTANT: The entire axle capacity (axle completely dry) is 7.4 qt (7 L). Each hub contains 0.80 qt (0.75 L) of lubricant. To protect the outer bearings from oil starvation, jack up (articulate) each side of the axle a minimum of 4 inches (10 cm) to ensure that oil flows to the outer bearings. Articulate the short-side arm for 45 seconds and the long-side arm for 90 seconds. After articulating the axle, add 0.80 qt (0.75 L) of lubricant through the fill hole (in addition to the 5.8 qt [5.5 L] of a normal oil change) for each hub that has been removed. Check the oil level again and ensure that the axle is neither under- nor over-filled.

4. Install the fill plug and tighten it securely.

Meritor Axle

1. Remove the filler plug, then the drain plug and allow the differential to drain completely.
2. Install the drain plug. Tighten it 24 lbf-ft (34 N-m).
3. Fill the differential with an S.A.E. 80W-90 multipurpose gear lubricant, or an S.A.E. 75W-90 multipurpose synthetic gear lubricant. See **Table 2** for axle lubricant capacities. Either type of lubricant must meet Military Specification L-2105-D and be suitable for American Petroleum Institute service classification GL-5. The

lubricant level within the differential must be even with the bottom of the fill hole.

4. Install the fill plug. Tighten it 24 lbf-ft (34 N-m).

Differential/Hubs	Capacity: qt (L)
Differential Only	5.8 (5.5)
Differential and Hubs	7.4 (7.0)

Table 1, ABP Drive Axle Lubricant Capacities

Meritor Drive Axle Lubricant Capacities (single axle)*	
Axle Model	Capacity: pt (L)†
RS-15-120	16 (7.6)
RS-17-145	33.6 (15.9)
RS-19-145	34.4 (16.3)
RS-21-145	32 (15.1)
RS-23-160	42 (19.9)
RC-23-165	42 (19.9)

* Single drive axles equipped with traction equalizers may require a "friction modifier" to correct a slip-stick condition, as described in the vehicle driver's manual. Meritor's experience shows that the following additives perform adequately: Add Elco No. 2 Friction Modifier (1 ounce [30 ml] of additive for each 1 pint [0.5 liter] of lube capacity) or Lubrizol No. 797 or 762 (one ounce [30 mL] of additive for each 1 pint [0.5 liter] of lube capacity).

† Quantities listed are approximate and include 1 pint (0.5 liter) for each wheel end and with the drive pinion at 3 degrees.

Table 2, Meritor Drive Axle Lubricant Capacities (single axle)

35-03 Axle Breather Checking

NOTE: On Freightliner axles, the axle housing breather is located on the carrier assembly.

The axle housing breather must remain unobstructed. Whenever the axle lubricant is checked or changed, also make sure that the breather is open. Check more often under poor operating conditions. If the breather is plugged, clean or replace it as needed. See [Fig. 2](#) and [Fig. 3](#).

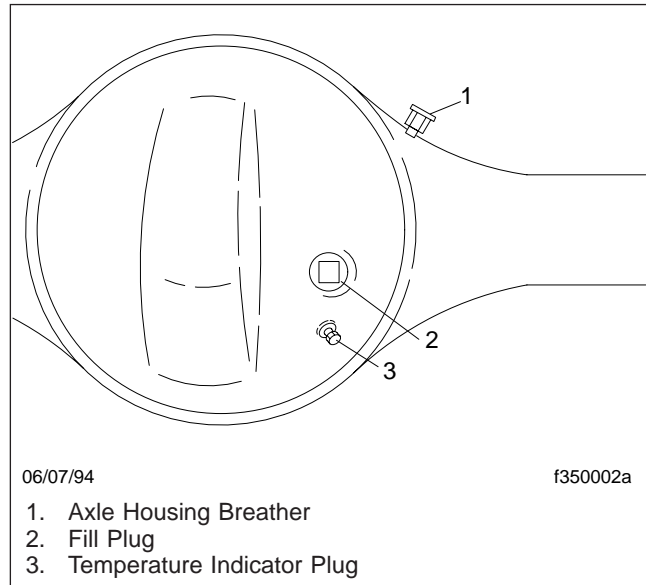

Fig. 2, Meritor Axle Housing (typical)

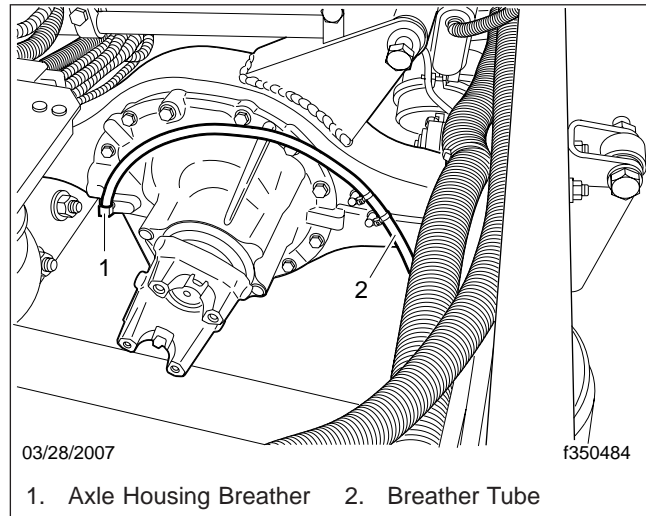

Fig. 3, Freightliner Axle Housing

Title of Maintenance Operation (MOP)	MOP Number
Wheel Cleaning and Polishing	40-02
Wheel Nut Checking	40-01

40-01 Wheel Nut Checking

IMPORTANT: In addition to the maintenance interval in this manual, check the wheel nut torque the first 50 to 100 miles (80 to 160 km) of operation after a wheel has been removed and installed.

NOTE: On each wheel stud, the end that faces away from the vehicle is stamped with an "L" or an "R," depending on which side of the vehicle the stud is installed. Studs stamped with an "L" are left-hand threaded and are installed on the driver's side of the vehicle. Studs stamped with an "R" are right-hand threaded and are installed on the passenger's side of the vehicle.

When checking wheel nuts on a dual disc assembly, remove one outer nut at a time, tighten the inner nut, then reinstall the outer nut. Repeat this procedure for all of the inner wheel nuts in the sequence shown in Fig. 1, Fig. 2, or Fig. 3. Then, tighten all of the outer wheel nuts in the same sequence.

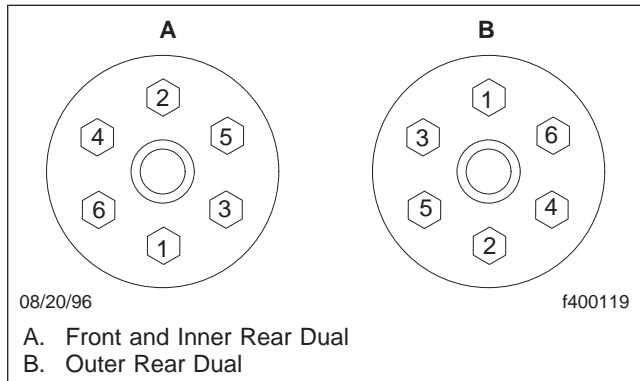

Fig. 1, Wheel Nut Tightening Sequence (6-stud hubs)

CAUTION

Too little wheel nut torque can cause wheel shimmy, resulting in wheel damage, stud breakage, and extreme tire tread wear. Too much wheel nut torque can break studs, damage threads, and crack discs in the stud hole area.

Tighten the wheel nuts.

- On 6-stud, stud-pilot hubs, tighten the wheel nuts 450 to 500 lbf-ft (610 to 678 N-m). See Fig. 1 for the tightening sequence.

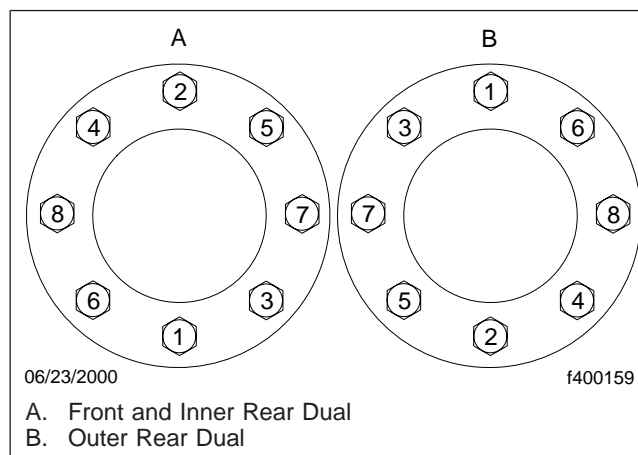

Fig. 2, Wheel Nut Tightening Sequence (8-stud hubs)

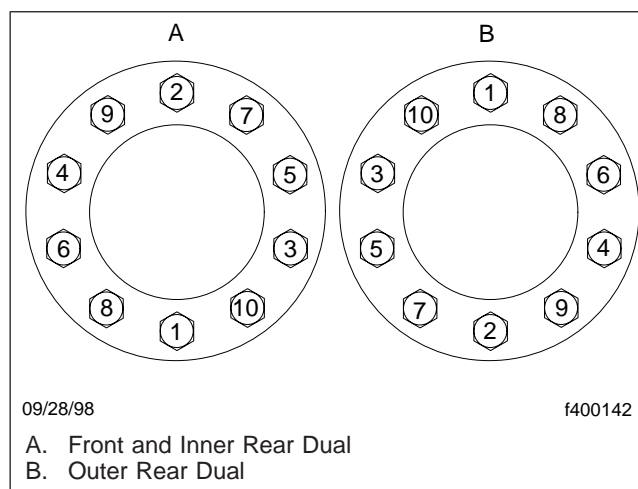

Fig. 3, Wheel Nut Tightening Sequence (10-stud hubs)

- On 8-stud or 10-stud, hub-pilot hubs with 20-mm studs, tighten the wheel nuts 280 to 310 lbf-ft (380 to 420 N-m). See Fig. 2 or Fig. 3 for the tightening sequence.
- On 8-stud or 10-stud, hub-pilot hubs with 22-mm studs, tighten the wheel nuts 450 to 500 lbf-ft (610 to 678 N-m). See Fig. 2 or Fig. 3 for the tightening sequence.

NOTE: Wheel nuts for 20-mm stud hubs require a 1- 3/16-inch (30-mm) socket. Wheel nuts for 22-mm stud hubs require a 1-5/16-inch (33-mm) socket.

40–02 Wheel Cleaning and Polishing

Accuride® Machined and Polished Aluminum Wheels

IMPORTANT: Do not scrub the wheels before rinsing off particles with high-pressure water. Synthetic cleaning pads and wire brushes should not be used to clean the wheels.

Do not use strong detergents, alkaline, or acidic cleaners to clean Accuride aluminum wheels. These solutions can etch the surface of the aluminum and leave dull areas. Abrasive polishes, or polishes not recommended for aluminum, should not be used on aluminum wheels.

1. Rinse the wheel with high-pressure water to remove debris.
2. Use a 100% cotton cloth dipped in a mild soap solution to help remove built up dirt and grease. Dish soap or automotive car wash soap are recommended.
3. Rinse the remaining soap residue from the wheel.
4. Dry the wheel thoroughly with a 100% cotton cloth.
5. Use a metal cleaner/polish that is compatible with aluminum to remove spots and stains from the surfaces of the wheel as necessary.
6. Apply carnauba wax to the visible wheel surfaces. Carnauba wax should be reapplied on a regular basis to maintain the wheel luster.

NOTE: Failure to apply a protective polish/wax/sealant will leave the polished surface susceptible to water spotting and/or pitting from environmental contaminants.

Title of Maintenance Operation (MOP)

MOP Number

Driveline Inspecting and Lubricating 41-01

41–01 Driveline Inspecting and Lubricating

Inspecting

Before lubricating the driveline U-joints and slip-joints, make the following checks.

1. Check that the yoke-strap capscrews are tightened 50 to 60 lbf-ft (68 to 81 N-m).

CAUTION

Do not overtighten the yoke-strap capscrews, due to the extreme load occurring at high-speed rotation. A loose or broken capscrew at any point in the driveline weakens the driveline connection, which could eventually result in serious vehicle damage.

2. Check the slip-joints for spline wear by trying to bend the sleeve-yoke and splined shaft back and forth. If looseness is greater than 0.007 inch (0.18 mm), replace both the sleeve-yoke and the splined shaft.
3. Check the driveshaft for missing balance weights, and for debris buildup. Remove any buildup. If any balance weights are missing, remove the driveshaft and have it balanced. For instructions, see **Group 41** of the *Recreational Vehicle Chassis Workshop Manual*, or take the vehicle to an authorized Freightliner dealer.
4. Check that the yoke plug is not loose or missing. Replace the yoke plug if needed. If the yoke plug is missing, the splined shaft may be hitting the yoke plug and knocking it out; check the driveshaft for proper length.

U-Joint Lubricating

1. Wipe all old grease and dirt from each U-joint grease fitting.
2. Use a hand-type grease gun, or a high-pressure gun with a low-pressure adaptor, to lubricate the U-joints.

NOTE: If a low-pressure adaptor is not used with the high-pressure gun, the U-joints may not receive enough lubricant.

3. Using lithium 12-hydroxy stearate grease (NLGI grade 1 or 2, with EP additives), lubricate until new grease can be seen at all four U-joint seals.

CAUTION

Fresh lubricant must be seen escaping from all four of the bearing cup seals of each U-joint. If not, the U-joint may fail prematurely.

4. If the bearing will not take grease, replace the U-joint assembly. For instructions, see **Group 41** of the *Recreational Vehicle Chassis Workshop Manual*, or take the vehicle to an authorized Freightliner dealer.
5. Check the old grease. If it appears rusty, gritty, or burned, replace the U-joint assembly. For instructions, see **Group 41** of the *Recreational Vehicle Chassis Workshop Manual*, or take the vehicle to an authorized Freightliner dealer.
6. Wipe any excess grease from the seals and grease fittings.

Slip-Joint Spline Lubricating

1. Wipe all old grease and dirt from the slip-joint grease fitting.
2. Use a hand-type grease gun or a high-pressure gun with a low-pressure adaptor, to lubricate the slip-joint. Using lithium 12-hydroxy stearate grease (NLGI grade 1 or 2, with EP additives), lubricate until fresh grease appears at the pressure-relief hole in the yoke plug. Then cover the relief hole with your finger, while continuing to lubricate until fresh grease appears at the slip-joint seal. This ensures complete lubrication of the splines.
3. Wipe any excess grease from the pressure-relief hole, slip-joint seal, and grease fitting.

Title of Maintenance Operation (MOP)	MOP Number
Air Dryer Desiccant and Coalescent Filter Replacing	42-03
Air Dryer Inspecting	42-02
Bendix Hydro-Max® Power Booster Checking (front-engine diesel chassis)	42-08
Brake Caliper Slide Pin Lubricating, Bosch Brakes (front-engine diesel chassis)	42-09
Brake Inspecting	42-12
Brake Lines Checking, Hydraulic Disc Brakes (front-engine diesel chassis)	42-10
Brake Lining Wear Checking, Hydraulic Disc Brakes (front-engine diesel chassis)	42-11
Brake System Valves Inspecting	42-01
Camshaft Bracket Bushing Lubricating	42-04
Foot Brake Valve Actuator Lubricating	42-06
Meritor Roller Pin Lubricating	42-07
Slack Adjuster Lubricating	42-05

42–01 Brake System Valves Inspecting

1. Clean the valve exterior and inspect it for corrosion and damage.
2. Inspect the air lines connected to the valve for signs of wear or damage. Replace the lines as needed.
3. Check the valve for leakage.
 - 3.1 Apply the service brakes and hold them on a full line pressure of at least 80 psi (500 kPa).
 - 3.2 Check the air line fittings for leaks; tighten or replace the fittings as needed.
 - 3.3 Coat the exhaust port and body of the valve with soapy water, and check for leakage. Leakage is excessive if it produces a 1-inch (25-mm) bubble within 5 seconds.

If the brake valve does not function as described above, or if leakage is excessive, replace it with a new or remanufactured unit. Repeat the leakage checks before placing the brake valve in service.

42–02 Air Dryer Inspecting

1. Check the reservoirs for moisture. A small amount (a teaspoon or less) is normal. Larger amounts may mean that the desiccant needs to be replaced. Check the mounting and connecting lines.
2. Tighten the fasteners that attach the air dryer to the vehicle. Use the following torque values.

28 lbf·ft (38 N·m) for SAE grade 5, 3/8–16 fasteners.

135 lbf·ft (183 N·m) for SAE grade 5, 5/8–11 fasteners.

Check all air lines, fittings, and electrical connections for damage, leakage, or looseness.
3. Replace damaged or leaking parts, and tighten loose fittings or electrical connections.

42–03 Air Dryer Desiccant and Coalescent Filter Replacing

NOTE: Desiccant change intervals may vary from vehicle to vehicle. Typical desiccant cartridge life is three years. However, if experience has shown that extended or shortened life has resulted on a particular installation, then the interval can be increased or decreased accordingly.

Replacement

1. Park the vehicle on a level surface. Apply the parking brakes and chock the tires.
2. Completely drain all air reservoirs. Air pressure gauges should read 0 psi (0 kPa).
3. Loosen the desiccant cartridge with a strap wrench at the base of the cartridge. Spin off the cartridge and discard it.
4. Remove the O-ring from the threaded neck and discard it.
5. Remove the coalescent filter and discard it.

IMPORTANT: Lubricate the new O-rings prior to installation.

6. Install the new small O-ring in the groove on the bottom of the new coalescent filter.
7. Insert the coalescent filter with the O-ring end going into the air dryer opening first. The end of the filter with the "X" will then be facing out.
8. Install the other new O-ring over the threaded neck of the desiccant cartridge.
9. Screw on the desiccant cartridge until resistance is detected. Then, tighten the cartridge 1/4 to 3/4 of a turn by hand.

Operational Check

1. Start the engine and build air pressure to 120 psi (827 kPa).
2. Listen for the purge valve to open and release air. A large volume of air will be expelled, followed by a slow flow of air lasting approximately 30 seconds.

3. Shut down the engine and remove the chocks from the tires.
4. Perform the inspections in [Maintenance Operation 42-02](#).

42-04 Camshaft Bracket Bushing Lubricating

Pump grease into the camshaft bracket bushing until it appears at the slack adjuster end of the bracket. See [Fig. 1](#).

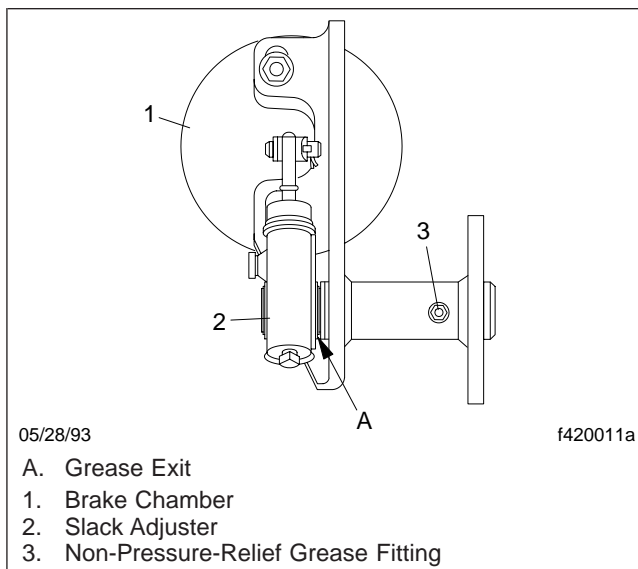

Fig. 1, Camshaft Bracket Bushing Lubrication

Use an NLGI Grade 1 or Grade 2 multipurpose chassis grease. If grease leaks out from under the cam head, the camshaft bracket grease seal is worn or damaged. For grease seal replacement instructions, see **Group 42** of the *Recreational Vehicle Chassis Workshop Manual*, or take the vehicle to an authorized Freightliner dealer.

Camshaft brackets without grease fittings are fitted with special seals and packed with extended-lubrication-interval chassis grease. Grease them only when the camshaft is disassembled for servicing.

42-05 Slack Adjuster Lubricating

IMPORTANT: Perform [Maintenance Operation 42-12](#) before lubricating the slack adjusters.

Automatic slack adjusters must be lubricated periodically to ensure proper brake operation.

WARNING

Failure to lubricate slack adjusters could lead to dragging brakes, or a brake failure, resulting in personal injury or property damage.

Gunite (IFS only)

Lubricate a Gunite automatic slack adjuster at the grease fitting until grease flows from the grease-relief opening.

For operating temperatures of -20°F (-29°C) and higher use Texaco Multifak EP-2 or Mobil Grease No. 77.

For operating temperatures between -20°F (-29°C) and -40°F (-40°C), use Lubriplate Aero grease.

Haldex

Lubricate a Haldex automatic slack adjuster at the grease fitting with any extreme-pressure NLGI Grade 1 or Grade 2 grease if the operating temperature is -20°F (-29°C) and above. If the operating temperature is below -20°F (-29°C), use a low-temperature extreme-pressure grease.

Meritor

Lubricate the slack adjuster at the grease fitting until grease is forced past the pressure-relief capscrew or past the gear splines around the inboard snap ring. Use high-temperature, NLGI Grade 1 waterproof grease. See [Fig. 2](#).

42-06 Foot Brake Valve Actuator Lubricating

1. Clean any dirt, gravel, and other foreign material from the base of the brake pedal, the plunger boot, and the brake base bracket.

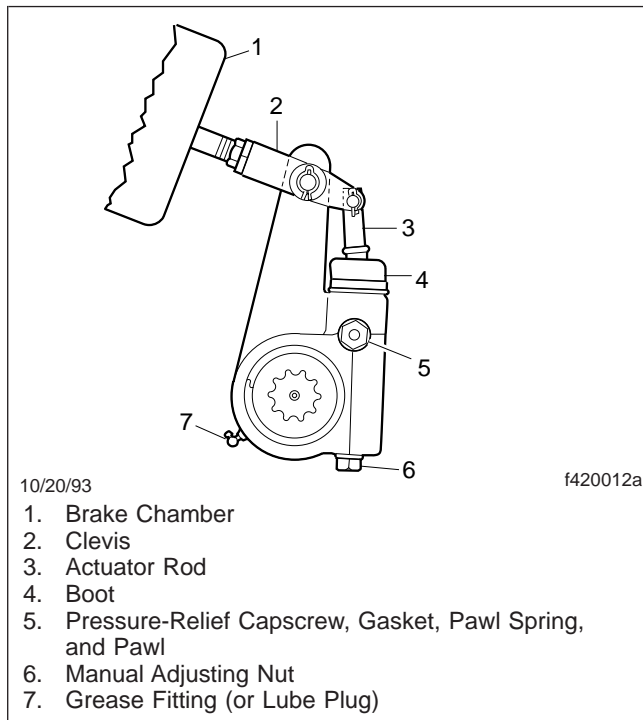

Fig. 2, Meritor Automatic Slack Adjuster (other slack adjusters are similar)

2. Use light oil to lubricate the brake pedal roller and pivot pin.
3. Check the brake plunger boot for cracks, holes, or deterioration. Replace it if necessary.
4. Lift the edge of the brake plunger boot and check the plunger for existing lubrication.
 - 4.1 If the plunger is dry, remove it by removing the brake pedal and brake plunger boot. Lubricate the plunger and the inside surface of the boot with barium grease (p/n BW 246671) or Pennzoil Adhezoplex EP2. Install the plunger, boot, and the brake pedal.

IMPORTANT: Use only these approved lubricants.

- 4.2 If the plunger has grease on it, lift the edge of the brake plunger boot enough to apply 2 to 4 drops of light oil around the brake plunger, where it slides into the brake base bracket. Install the plunger boot around the brake base bracket.

42-07 Meritor Roller Pin Lubricating

⚠ WARNING

Remove all grease or oil from the camshaft head, rollers and brake linings. Always replace linings contaminated with grease or oil, which can increase stopping distances, causing component damage and serious personal injury.

For Q and P series Meritor brakes, lube the cam anchor and cam roller pins when the brake is disassembled or every six months with Meritor specification grease 0-617-A or 0-617-B. See [Fig. 3](#) for roller and anchor pin lubrication points.

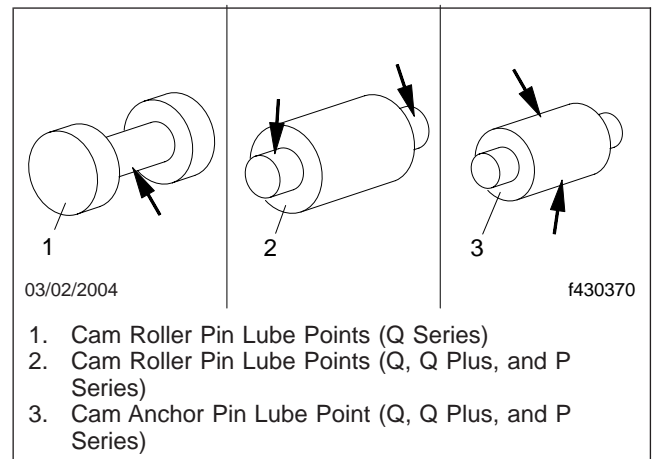

Fig. 3, Cam and Anchor Roller Pin Lubrication Points

42-08 Bendix Hydro-Max[®] Power Booster Checking (front-engine diesel chassis)

Check for proper operation; see **Group 42** of the *Recreational Vehicle Chassis Workshop Manual* for instructions, or take the vehicle to an authorized Freightliner dealer.

42-09 Brake Caliper Slide Pin Lubricating, Bosch Brakes (front-engine diesel chassis)

NOTE: There is no set maintenance interval for lubricating pin-slide hydraulic disc brake calipers.

Apply 1/8 oz (3.5 g) Aeroshell grade 5 grease to each of the two guide pin and guide pin bore sets. See the *Bosch Pin Slide Disc Brakes Service Manual* for additional information.

IMPORTANT: The later ZOH-T caliper has important differences from the early ZOPS caliper. ZOPS calipers (since 1998) and ZOH-T calipers (since 2002) use different slide pins and bolts. See [Fig. 4](#) and [Fig. 5](#). The later trailing pin is identified by notches and has a rubber bushing. Flange-head instead of hexhead bolts are used with the later caliper. The later bolts have a fine thread rather than a coarse thread pitch, are longer, differently colored, and are tightened to a higher torque specification. Use only the ZOH-T bolts to assemble a ZOH-T caliper. The ZOPS caliper bolts have a different thread pitch and will not assemble correctly in a ZOH-T caliper mounting. Also, the ZOH-T bolts will not assemble correctly in a ZOPS caliper. **Do not interchange parts.** It is permissible to use both ZOH-T pins and ZOH-T bolts in a ZOPS anchor plate, but they must be replaced as sets. Both the pins and the bolts must be changed.

DANGER

The correct pins, bolts, and bolt torque must be used. If not, brake function could be impaired and lead to loss of control of the vehicle, which could result in personal injury, death, or property damage.

IMPORTANT: The ZOH-T caliper assembly is similar in appearance to the existing ZOPS caliper. The only obvious difference is that one of the anchor plate slide pins (trailing side) has notches for identification. With ZOH-T calipers, install the solid pin (no bushing) only in the an-

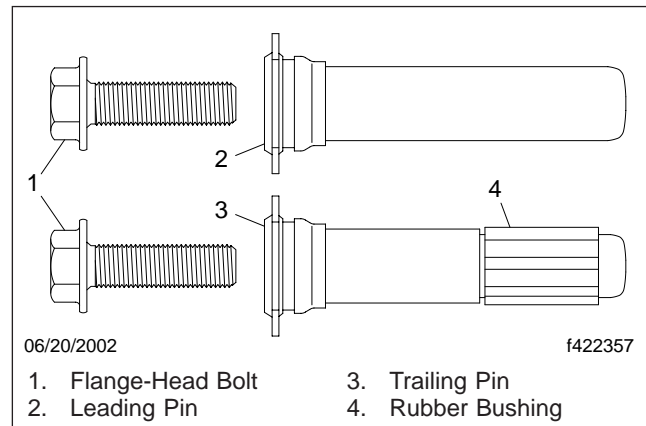

Fig. 4, ZOH-T Slide Pins and Bolts

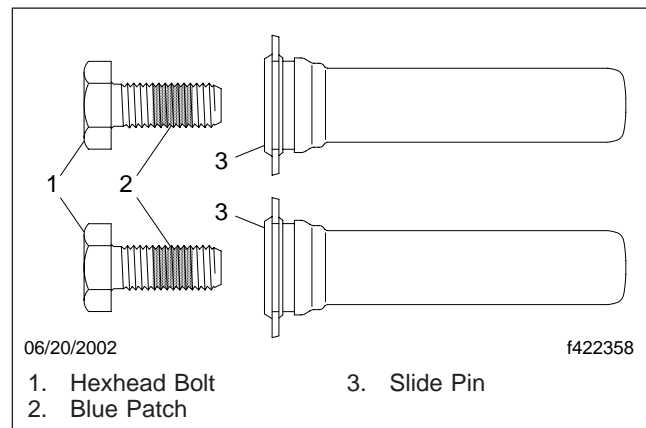

Fig. 5, ZOPS Slide Pins and Bolts

chor plate leading hole position. Install the pin with the rubber bushing and notches only in the anchor plate trailing hole position. Tighten the leading-side pin first, then tighten the trailing-side pin.

Tighten ZOH-T bolts 93 to 107 lbf-ft (126 to 145 N·m).

Tighten ZOPS bolts 70 to 80 lbf-ft (95 to 108 N·m).

42–10 Brake Lines Checking, Hydraulic Disc Brakes (front-engine diesel chassis)

Check all hydraulic lines and fittings for damage, leakage, or looseness.

Replace damaged or leaking components, and tighten loose fittings.

42–11 Brake Lining Wear Checking, Hydraulic Disc Brakes (front-engine diesel chassis)

Before checking lining wear with the wheel removed, review the following brake lining exposure warnings.

WARNING

Breathing brake lining dust (asbestos or non-asbestos) could cause lung cancer or lung disease. Unless exposure can be reduced below legal limits, wear an air purifying respirator approved by MSHA or NIOSH at all times when servicing the brakes, starting with removal of the wheels and continuing through assembly.

To minimize the possibility of creating airborne brake lining dust, clean the dust from the brake rotor, brake caliper, and brake assembly, using an industrial-type vacuum cleaner equipped with a high-efficiency filter system. Then, using a rag soaked in water and wrung until nearly dry, remove any remaining dust. Do not use compressed air or dry brushing to clean the brake assembly.

1. Apply the brake and chock the tires to prevent vehicle movement.
2. Check the brake lining wear. On front and rear axles, replace linings worn to less than 3/16 inch (4.8 mm).
3. Make sure that the brake rotor and linings are free of oil and grease.

NOTE: To replace the brake linings, see the applicable foundation brake section in **Group 42** of the *Recreational Vehicle Chassis Workshop*

Manual, or take the vehicle to an authorized Freightliner dealer.

42–12 Brake Inspecting

IMPORTANT: This procedure should be performed prior to lubrication of the brake components.

Parking Brake Operational Check

CAUTION

Perform the following check in a clear safe area. If the parking brakes fail to hold the vehicle, personal injury or property damage may result.

1. With the engine running, and air pressure at cut-out pressure, set the parking brake.
2. Put the vehicle in the lowest gear and gently attempt to move it forward. The vehicle should not move. If the vehicle moves, the parking brakes are not operating correctly and must be repaired before the vehicle is returned to service. See **Group 42** of the *Recreational Vehicle Chassis Workshop Manual* for repair procedures, or take the vehicle to an authorized Freightliner dealer.

Brake Component Inspection

1. Park the vehicle on a level surface, set the parking brake, and chock the tires. Once the tires are chocked, release the parking brake.

WARNING

Manually adjusting an automatic slack adjuster to bring the pushrod stroke within legal limits is likely masking a mechanical problem. Adjustment is not repairing. Before adjusting an automatic slack adjuster, troubleshoot the foundation brake system and inspect it for worn or damaged components. Improperly maintaining the vehicle braking system may lead to brake failure, resulting in property damage, personal injury, or death.

2. With the engine off, and 100 psi (689 kPa) of air tank pressure, have an assistant apply and hold an 80 to 90 psi (550 to 620 kPa) brake application.

3. Check to see if the colored over-stroke band on each brake chamber pushrod is exposed.

If a band shows, the stroke is too long. Check the foundation brake components for wear or damage, and repair as needed. See **Group 42** of the *Recreational Vehicle Chassis Workshop Manual* for inspection, troubleshooting, and repair procedures, or take the vehicle to an authorized Freightliner dealer.

4. Measure the applied chamber stroke. See **Table 1** for the proper stroke for the type of chamber being used. If the stroke is too short, the brakes may drag or will not fully apply. Check for improper operation or adjustment of the auto-

matic slack adjuster. See **Group 42** of the *Recreational Vehicle Chassis Workshop Manual* for inspection and troubleshooting procedures, or take the vehicle to an authorized Freightliner dealer.

5. Start the engine and build air pressure to at least 100 psi (689 kPa). Shut down the engine.
6. Check all of the foundation brake components for damage, wear, and loose or missing parts. Repair as needed. See **Group 42** of the *Recreational Vehicle Chassis Workshop Manual* for repair procedures, or take the vehicle to an authorized Freightliner dealer.

Brake Chamber Stroke Specifications			
Chamber			Max Applied Stroke: inch (mm)
Manufacturer	Type*	Size†	
Gunit	Standard Stroke	9	1-3/8 (35)
		12	
		16	1-3/4 (45)
		20	
		24	
		30	
	36‡	2-1/4 (57)	
	Long Stroke	16	2 (51)
		20	
		24 (2-1/2 inch rated stroke)	
24 (3 inch rated stroke)		2-1/2 (64)	
30			
Hallex	Standard Stroke	12	1-3/8 (35)
		16	1-3/4 (44)
		20	
		24	
	2-1/2-Inch Extended Stroke	24	2 (51)
	3-Inch Extended Stroke	24	2-1/2 (64)
	Standard Stroke	30	2 (51)
	Long Stroke	30	2-1/2 (64)

Brake Chamber Stroke Specifications			
Chamber			Max Applied Stroke: inch (mm)
Manufacturer	Type*	Size†	
Meritor	Standard Stroke	9	Less than 1-1/2 (38)
		12	
		16	
		20	Less than 1-3/4 (44)
		24	
	Long Stroke	24	Less than 1-7/8 (48)
	Standard Stroke	30	

* Long stroke design is indicated by a tag, or embossing, on the brake chamber.

† Specifications are relative to a brake application with 80 to 90 psi (550 to 620 kPa) air pressure in the brake chambers.

‡ If type 36 chamber is used, slack length should be less than 6 inches.

Table 1, Brake Chamber Stroke Specifications

Title of Maintenance Operation (MOP)	MOP Number
Drag Link Lubricating	46-01
Hydraulic Reservoir Filter Changing (metal reservoir only)	46-06
Power Steering Reservoir Fluid Level Checking	46-02
Power Steering Reservoir Fluid and Filter Changing	46-03
Steering Driveline Lubricating	46-04
Steering Gear Lubricating	46-05

46–01 Drag Link Lubricating

1. Using a clean rag, wipe the dirt from both grease fittings on the drag link.
2. Using a pressure gun, apply multipurpose chassis grease at the grease fittings until old grease is forced out of the socket.

NOTE: Use multipurpose chassis grease NLGI grade 1 (6% 12-hydroxy lithium stearate grease) or NLGI grade 2 (8% 12-hydroxy lithium stearate grease). The grade 2 chassis grease is preferred.

46–02 Power Steering Reservoir Fluid Level Checking

1. Clean around the power steering reservoir dipstick (fill cap) with a clean rag, then remove the dipstick.

WARNING

Fill only with approved clean fluid. Do not mix fluid types. Any mixture or any unapproved fluid could lead to seal deterioration and leaks. Fluid leakage could cause loss of power steering assist, possibly resulting in personal injury and property damage.

2. With the power steering fluid at operating temperature, check the fluid level on the dipstick. If below the "Add" mark, add enough fluid to bring the level up to the "Full" mark on the dipstick. See [Table 1](#) for approved power steering fluid.

Fluid Type	Approved Fluid*
Automatic Transmission Fluid	Dexron VI
Hydraulic System Fluid (power steering with side-mounted radiator)	15W40

* Use the same lubricant when assembling parts as is used in the power steering system.

Table 1, Approved Power Steering Fluid

3. Install the dipstick (fill cap) in the power steering reservoir.

46–03 Power Steering Reservoir Fluid and Filter Changing

1. Remove the dipstick, if so equipped.
2. Drain the power steering reservoir by disconnecting the power steering gear-to-reservoir hose from the reservoir. Catch the fluid from the reservoir in a drain bucket, then cap the reservoir port.
3. Loosen the clamps on each end of the inline power steering filter and save them for reuse. Remove the old filter, if so equipped.

IMPORTANT: Do not use teflon tape on the threads of the hose-barb fittings.

4. Unscrew the hose-barb fitting and the 90-degree hose-barb elbow fitting from the old filter and inspect them for any damage. If no damage is found, screw the two fittings into the new 25-micron filter. If damage is found in the fittings, replace them with a new 1/2–14 NPT hose-barb fitting and elbow.

IMPORTANT: Ensure that the "TO RESERVOIR" arrow on the power steering filter, if so equipped, is pointing towards the power steering fluid reservoir and that the hose-barb 90-degree elbow fitting is located on the bottom of the power steering filter. See [Fig. 1](#).

5. Place the ends of the power steering gear-to-reservoir hose onto the hose-barb fittings and tighten the two hose clamps securely.

WARNING

Fill only with approved clean fluid. Do not mix fluid types. Any mixture or any unapproved fluid could lead to seal deterioration and leaks. Fluid leakage could cause loss of power steering assist, possibly resulting in personal injury and property damage.

6. Fill the reservoir with approved power steering fluid. See [Table 1](#).
7. Place the disconnected end of the steering gear-to-reservoir hose in a drain bucket. *Do not start the engine while draining the system.* Raise the front of the vehicle with a floor jack and support

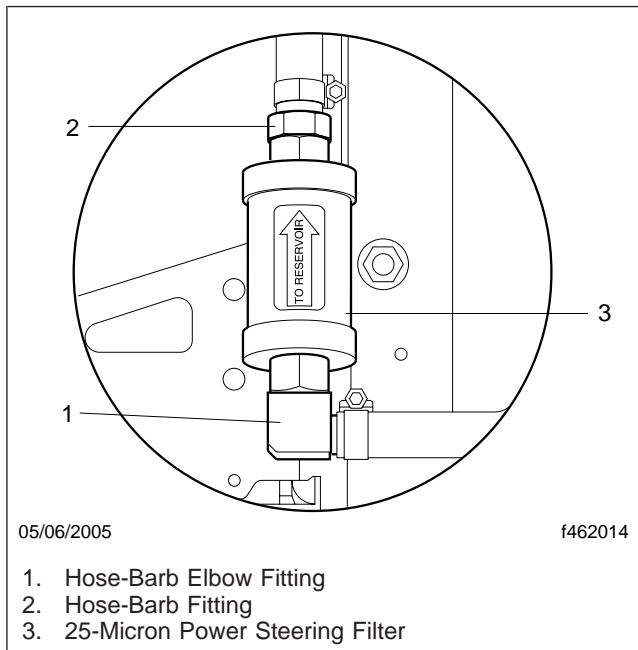

Fig. 1, Power Steering Filter, Typical Installation (if so equipped)

it with jack stands. Have an assistant turn the steering wheel to full lock left and right, and capture the fluid flowing from the hose in the drain bucket. Add fluid to the reservoir as needed. Continue turning the steering wheel until clean power steering fluid flows from the hose into the drain bucket. Remove the plug from the reservoir and reconnect the steering gear-to-reservoir hose to the reservoir.

8. Tighten the hose fitting nut finger-tight, then with a wrench, tighten until there is firm resistance. Tighten one-sixth turn more. Do not overtighten. Remove the jack stands and lower the vehicle.
9. Fill the reservoir with approved fluid as needed. Start the engine and let it idle for 10 seconds. Have an assistant turn the steering wheel from lock-to-lock until no bubbles are seen in the reservoir. Shut down the engine.
10. Install a new cover gasket, the cover, and the dipstick.
11. Start the engine and check the power steering reservoir fluid level. If the fluid level is low, add more of the approved fluid to bring the level up to the full mark on the dipstick. Turn the steering

wheel from lock-to-lock to flush out any air. Shut down the engine.

46-04 Steering Driveline Lubricating

Wipe the grease fittings clean. Using a pressure gun, apply a lithium-based grease (NLGI grade 2) sparingly to the universal joints and slip-joint splines.

46-05 Steering Gear Lubricating

1. Wipe off debris from the grease fitting.
2. Using a hand-type grease gun, apply multipurpose chassis grease until the grease starts coming out of the sector shaft dirt and water seal.

46-06 Hydraulic Reservoir Filter Changing (metal reservoir only)

NOTE: On XC chassis vehicles with a side-mounted radiator, the hydraulic reservoir supplies both the steering and the fan circuits.

1. Drain the entire steering and fan hydraulic systems.
2. Remove the reservoir lid and remove the nut that secures the filter.
3. Remove the old filter and install the new filter.
4. Install the filter nut and tighten it securely.
5. Fill the reservoir with the approved hydraulic fluid. See [Table 1](#)
6. Start the engine, run it for five seconds, then shut down the engine.
7. Fill the reservoir with 15W40 hydraulic system fluid.
8. Start the engine. Turn the steering wheel lock-to-lock several times until the steering wheel turns easily. Shut down the engine.
9. Fill the reservoir with 15W40 hydraulic system fluid.

NOTE: The steering circuit is now purged. Follow the remaining steps to purge the fan circuit.

10. Start the engine. Run the engine at half-throttle until the fans engage (loud chirping sound). Shut down the engine.
11. The fan circuit is now purged. Top off the reservoir fluid and install the reservoir lid.

Title of Maintenance Operation (MOP)	MOP Number
Fuel Tank Mounts and Fuel Line Checking	47-01
Fuel/Water Separator Element Replacing	47-02
Inline Fuel Strainer Replacing, Cummins ISB02 Engine	47-03

47–01 Fuel Tank Mounts and Fuel Line Checking

 **WARNING**

Inspect the components as described below. Failure to perform these inspections could result in the failure of the fuel tank mounting assembly and loss of vehicle control, possibly causing personal injury or death, or property damage.

1. Chock the tires. Working at the front of the vehicle or at the rear of the vehicle, raise the vehicle so that the tires just clear the ground and so that the suspension is fully extended. Place safety stands under the vehicle frame.
2. Check the T-bolts that attach the fuel tank mounting straps to the mounting brackets. Check to see that the nuts are tight.
3. Inspect the fuel tank straps for damage or wear. Replace them if necessary.
4. Inspect the fuel tank for leaks or damage. Replace the tank if necessary.

IMPORTANT: Do not attempt to repair a damaged fuel tank; always replace a damaged fuel tank.

5. Inspect the fuel lines for damage or wear.
6. Remove the safety stands and lower the vehicle. Remove the chocks from the tires.

47–02 Fuel/Water Separator Element Replacing

1. Chock the front tires.
2. Locate the fuel/water separator.
3. See the *Cummins Operation and Maintenance Manual* for fuel/water separator element replacing intervals.
4. Remove the chocks from the tires.

47–03 Inline Fuel Strainer Replacing, Cummins ISB02 Engine

NOTE: Vehicles with a Cummins ISB02 engine have an inline fuel strainer located inside the rail on the right-hand side above the rear axle. On front-engine diesel chassis, the fuel strainer is located inside the rail on the left-hand side behind the shock.

The inline fuel strainer does not apply to EPA07 vehicles.

1. Remove the brackets on each end of the fuel strainer.
2. Remove the P-clip.

IMPORTANT: The fuel flow arrow on the fuel strainer must be pointed toward the engine.

3. Remove the strainer, and replace it with a new strainer.
4. Install the P-clip.
5. Install the brackets on each end of the fuel strainer.

Title of Maintenance Operation (MOP)

MOP Number

Exhaust System Inspecting. 49-01

49–01 Exhaust System Inspecting

The exhaust system must be free of leaks, binding, grounding, and excessive vibrations.

These conditions are usually caused by loose, broken, or misaligned clamps, brackets, or pipes. If any of these conditions exist, check the exhaust system components and alignment. Align or replace as necessary. For alignment or adjustment instructions, see **Group 49** of the *Recreational Vehicle Chassis Workshop Manual*, or take the vehicle to an authorized Freightliner dealer.

IMPORTANT: The Environmental Protection Agency's 2007 regulations require lower exhaust emissions, thus requiring new exhaust system components. See **Fig. 1**. In particular the aftertreatment device (ATD), which is part of the aftertreatment system (ATS), requires special attention during regularly scheduled maintenance inspections. If any discrepancies are discovered, refer to the engine manufacturer's service literature for repair instructions.

Definitions of ATS Components

Refer to the following list of definitions of ATS components.

- Aftertreatment System (ATS) — the entire exhaust system from the turbocharger to the exhaust stack or tail pipe.
- Aftertreatment Device (ATD) — a muffler-like canister that houses a DPF and sensors.
- Diesel Particulate Filter (DPF) — a filter that collects and holds particulate matter (soot and ash).
- Diesel Oxidation Catalyst (DOC) — oxidizes hydrocarbons and reduces NOx.
- Sensors — detect temperatures and pressure within the ATS.
- Diffuser — a device, used as a deflector, for distributing, mixing, and reducing the velocity of air flow.

Inspection

1. Check for leakage at the clamp that attaches the exhaust pipe to the turbocharger exhaust outlet. If leakage exists, tighten the nut on the clamp to the required torque. If leakage persists, install a new clamp.
2. Check the exhaust pipe, bellows, and each exhaust seal clamp for leakage, wear, cracks, or damage. Replace damaged components as needed. If leakage exists at a clamp, tighten the nuts to the required torque. If leakage persists, install a new exhaust seal clamp. Do not reuse seal clamps. Once a seal clamp is loosened or removed, it must be replaced.
3. If present, check the condition of the insulation material around the exhaust pipe between the turbocharger and the ATD, as well as the exhaust wrap from the ATD to the diffuser.
4. Check the ATD mounting bands for tightness. Tighten to 30 lbf-ft (41 N-m) if needed. Do not overtighten.
5. Check for leaks around the clamps that attach the ATD in the ATS, and around the clamps that retain the DPF in the ATD. No leaks are allowed anywhere in the system.
6. Check all sensors attached to the ATD for leaks or damaged wires. No leaks are allowed.
7. Check the DPF exterior surface for dents or other damage. See **Fig. 1**, Item A. A dent over 3 inches (76 mm) in diameter and 1/4-inch (6-mm) deep could cause internal damage to the DPF, causing it to malfunction.
8. Check for heat discoloration on the surface of the ATD. Heat discoloration may indicate internal damage; especially around the DPF.
9. Check any wires, lines, or hoses within 4 inches (10 cm) of the exhaust system for heat damage. Repair or reroute as needed.

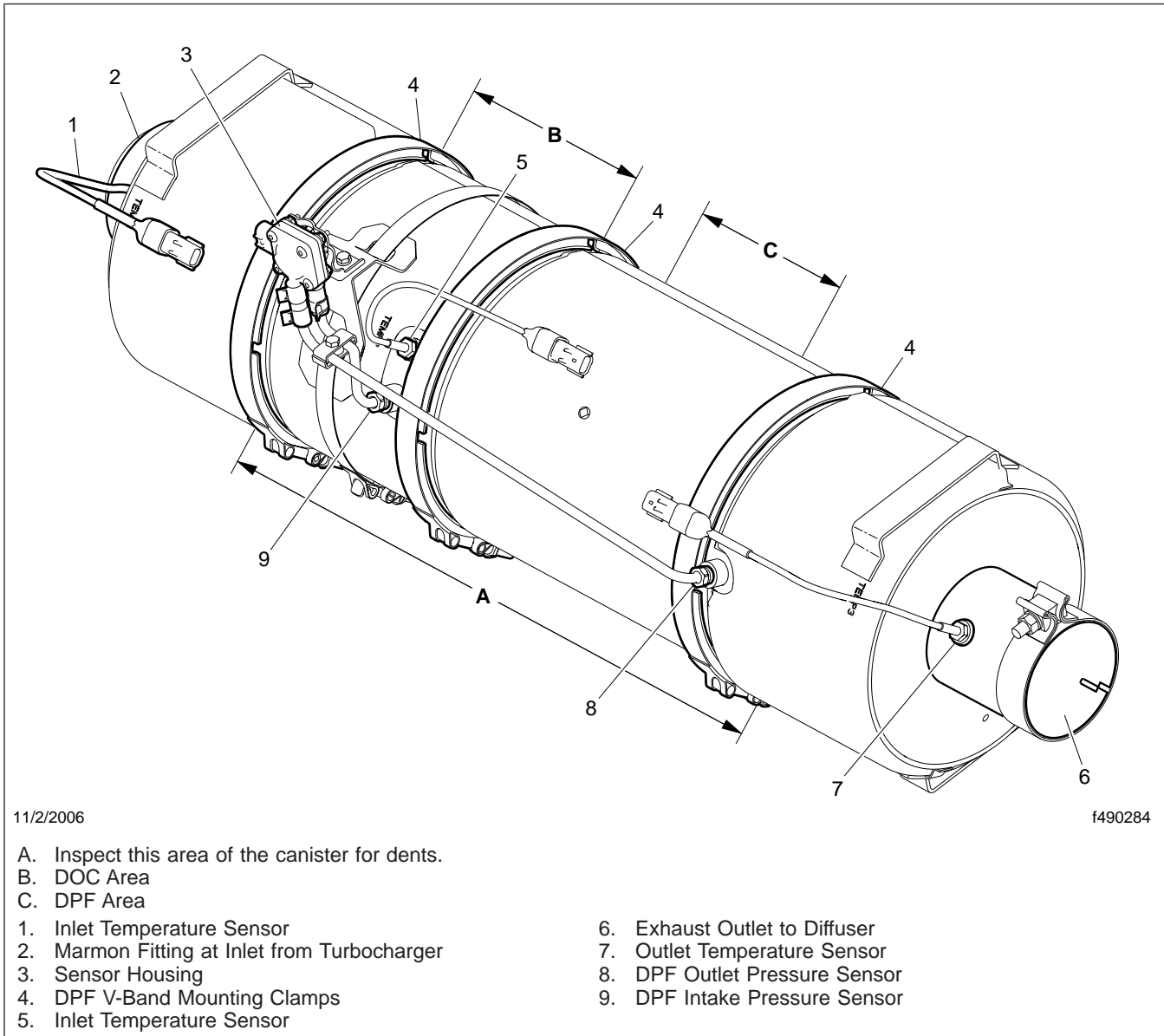

Fig. 1, Cummins Aftertreatment Device

Title of Maintenance Operation (MOP)	MOP Number
Battery Voltage Checking	54-02
Ground Cables Checking and Cleaning	54-01

54–01 Ground Cables Checking and Cleaning

Check that the ground cables are clean, undamaged, and tight. If needed, disconnect them, clean the mating surfaces with a soda solution, then connect them securely. Spray the ground cable connections with dielectric red enamel. See [Table 1](#) for approved part numbers.

Material	Part Number
Dielectric Grease	48–02349–000
Dielectric Red Enamel Spray	MMM 1602 IVI Spray-Sealer (Spray-On B–6–665)

Table 1, Approved Dielectric Grease and Red Enamel

54–02 Battery Voltage Checking

Check the battery open circuit voltage using an accurate voltmeter. If the voltmeter registers 12.5V or below, fully charge the battery to 12.65V. A fully charged battery will have a voltage of 12.65V with the charger disconnected.

Title of Maintenance Operation (MOP)

MOP Number

Air Conditioner Inspecting 83-01

83–01 Air Conditioner Inspecting

⚠ WARNING

Wear eye protection, gloves, and protective clothing when working on the air conditioning system. Leaking refrigerant from a damaged hose or line could cause blindness or serious skin burns.

1. Park the vehicle on a level surface, shutdown the engine, apply the parking brake, and chock the tires.

⚠ CAUTION

To avoid the possibility of burns, make certain that the engine and air conditioner components are not hot.

2. Check the appearance of the air conditioner compressor pulley assembly. If the friction surface of the pulley shows signs of excessive grooving due to belt slippage, replace both the pulley and the drive plate. Visually inspect the refrigerant compressor drive belt for damage, and check that the belt is set at the proper tension. Also check the tightness of the compressor mounting fasteners. For instructions and torque values and for removal and installation procedures, see **Group 83** of the *Recreational Vehicle Chassis Workshop Manual*, or take the vehicle to an authorized Freightliner dealer.
3. Inspect the drive plate. If the friction surface of the drive plate shows visible signs of damage due to excessive heat, replace the drive plate and pulley assembly. See **Group 83** of the *Recreational Vehicle Chassis Workshop Manual* for removal and installation procedures, or take the vehicle to an authorized Freightliner dealer.
4. On a Sanden refrigerant compressor, use a feeler gauge to check the drive plate clutch clearance. It should be 0.016 to 0.03 inch (0.4 to 0.8 mm). See **Fig. 1**. If the drive plate clutch requires adjustment, see **Group 83** of the *Recreational Vehicle Chassis Workshop Manual*, or take the vehicle to an authorized Freightliner dealer.
5. Inspect the compressor clutch coil wire. Ensure that the connector is not damaged or loose. Replace the wire if it is damaged.
6. Check the overall condition of the air conditioning hoses. Look for cracks, cuts, and abrasions on the hoses. Replace damaged hoses; see **Group 83** of the *Recreational Vehicle Chassis Workshop Manual* for replacement instructions, or take the vehicle to an authorized Freightliner dealer. Also, check for loose fittings on all air conditioning components.
7. Check for a buildup of road debris on the condenser fins. For cleaning instructions, see **Section 83.00, Subject 110**, of the *Recreational Vehicle Chassis Workshop Manual*, or take the vehicle to an authorized Freightliner dealer.

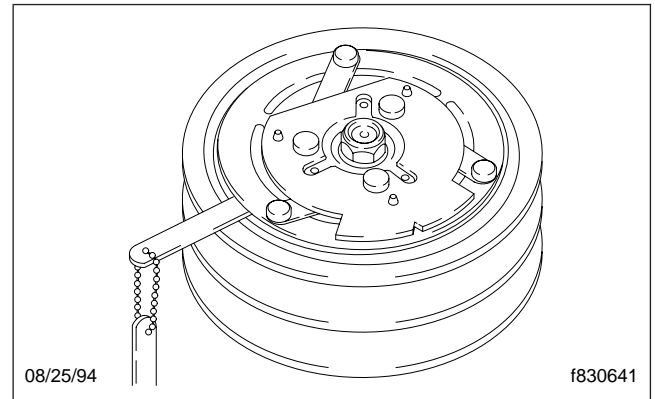

Fig. 1, Drive Plate Clearance Inspection (Sanden compressor shown)