

# Vansco Multiplex Module (VMM) 2820

Hardware Manual





Vansco Electronics  
1305 Clarence Ave  
Winnipeg MB R3T 1T4  
Canada

Tel: 204.452.6776  
Fax: 204.478.1749  
<http://www.vansco.ca>  
[info@vansco.ca](mailto:info@vansco.ca)

**Copyright 2007 © Vansco Electronics LP.** All rights reserved. No part of this work may be reproduced, published, or distributed in any form or by any means (electronically, mechanically, photocopying, recording, or otherwise), or stored in a database retrieval system, without the prior written permission of Vansco Electronics LP in each instance.

## Table of Contents

<b>1. Introduction</b> .....	<b>5</b>
1.1. Conventions .....	5
1.2. User Liability & Safety.....	5
<b>2. VMM Overview</b> .....	<b>7</b>
2.1.1. Physical Dimensions.....	8
<b>3. VMM Hardware</b> .....	<b>9</b>
3.1. VMM Inputs .....	9
3.2. VMM Outputs .....	10
3.3. VMM Communications.....	11
3.4. VMM Addressing .....	12
3.5. VMM Diagnostic LEDs.....	13
<b>4. VMM Operation</b> .....	<b>15</b>
4.1. Reading Inputs.....	15
4.2. Switching Outputs.....	15
4.3. Output Fault Monitoring .....	15
4.4. CAN Communications .....	16
4.5. LED Diagnostics .....	16
4.6. Vehicle Configuration Ladder Logic Programming.....	17
4.7. Plug and Play Automatic Module Programming.....	17
4.8. CAN Diagnostics.....	18
<b>5. VMM Setup and Use</b> .....	<b>19</b>
5.1. Input Considerations.....	19
5.2. Address Considerations.....	20
5.3. Output Considerations .....	21
5.4. Power Considerations.....	22
5.4.1. Cable Grounded System .....	22
5.4.2. Chassis Grounded System.....	23
5.5. Communication Considerations.....	25
5.6. General Considerations .....	26
<b>6. VMM Specifications</b> .....	<b>28</b>
6.1. Electrical/Environmental .....	28
6.2. Design Verification Standards .....	30
<b>7. VMM Connectors</b> .....	<b>43</b>
7.1. Input Connectors .....	43
7.1.1. 35 Pin Input Connector (J1).....	43
7.1.2. 23 Pin Input Connector (J2).....	45

7.2. Output Connectors .....	45
7.2.1. 35 pin output connector (J3) .....	46
7.2.2. 3 pin output connector.....	47
<b>8. Feedback .....</b>	<b>49</b>

# 1. Introduction

---

Historically, vehicle controls are not intelligent. Outputs are connected directly to switch inputs through wires. Relays may be used to boost current, but that is still essentially point-to-point wires. Building and installing the wire harness required to do this in a modern vehicle is very time consuming. Performing diagnostics is extremely difficult.

An alternative is to distribute small intelligent controllers that act as networked relay controllers throughout the vehicle. The modules communicate with each other over a network and monitor each other's status. In a multiplexed module system, when a switch is activated at the front of a vehicle, a module near that switch detects the transition and broadcasts the switch position over the network. The module connected to the load receives this information and activates the load.

This user guide will introduce the Vansco Multiplex Module and describe its use in a typical vehicular electrical system. The aim of the document is to provide a full specification for the VMM and give the reader the tools to use it to its full potential.

## 1.1. Conventions

Warnings and cautions will appear throughout this user manual.

A warning or caution indicates that a situation exist that could cause injury to a person or persons and/or damage to the vehicle or VMM product. A warning may also indicate situations where certain VMM functions may not operate properly if instructions are not followed. All instructions in the warnings through out this manual must be read and completely understood by the installer of the VMM system.

## 1.2. User Liability & Safety

The designer of a system or vehicle in which the VMM electronic control modules are installed has the full responsibility for all consequences that might occur. Vansco Electronics LP accepts no responsibility for any consequences, direct or indirect, caused by system failures or malfunctions.

- Vansco Electronics LP does not assume any responsibility for accidents or damage caused by incorrectly mounted or maintained equipment.
- Vansco Electronics LP does not assume any responsibility for damage or injury caused by VMM products being incorrectly applied or the system being programmed in a manner that jeopardizes safety.
- Vansco Electronics LP does not assume any responsibility for damage to VMM products which have not been 100% electrically disconnected from the system wire harness prior to welding on the vehicle or system in which it is installed.

## 2. VMM Overview

---

The VMM is a general-purpose multiplexed input/output controller designed to allow several digital and analog inputs to control several solid state switch outputs according to a logic table or vehicle configuration table. All VMM input and output information is communicated on a Controller Area Network (CAN) communication bus which allows inputs from one module to control outputs from another module, and vice versa. This flexibility is the heart of vehicle multiplexing:

Multiplexing reduces complexity by transmitting multiple messages over a single channel. This means taking a large number of inputs or wires, and reducing them to a smaller number while retaining all the information originally available. This technique allows simplification of complex systems without loss of performance.

Thus, a VMM located close to several control inputs on a vehicle (for example, next to the dashboard switches) could communicate the input states to a second VMM located close to the loads or outputs they are intended to control (for example, lights or loads at the rear of the vehicle). The communication cable that connects the VMMs is a shielded twisted pair cable (two wires covered with a shield for electrical noise protection). In essence, this example converts several dashboard switch wires running the length of the vehicle to two wires. The example above is very simple, and in fact there would typically be several VMMs in a vehicle electrical system, each located to help to reduce the complexity of the electrical system.

The VMM is designed to conform to the Society for Automotive Engineers (SAE) and the American Society of Agricultural Engineers (ASAE) standards. Specifically the VMM is designed to meet SAE J1455 and ASAE EP455 environmental and electrical standards and to SAE J1939 CAN communication standards. Each VMM is sealed and can withstand harsh environments including temperature ranges from -40C to +85C, pressure wash, and EMC susceptibility, to name a few.

The VMM arose from years of experience in the vehicular electronic control market. It has been designed to facilitate vehicle integration, reduce vehicle wiring and complexity, improve vehicle diagnostics, and enhance customers' ability to upgrade vehicle electronic systems.

### 2.1.1. Physical Dimensions

The following diagrams show the physical dimensions of the VMM2820:

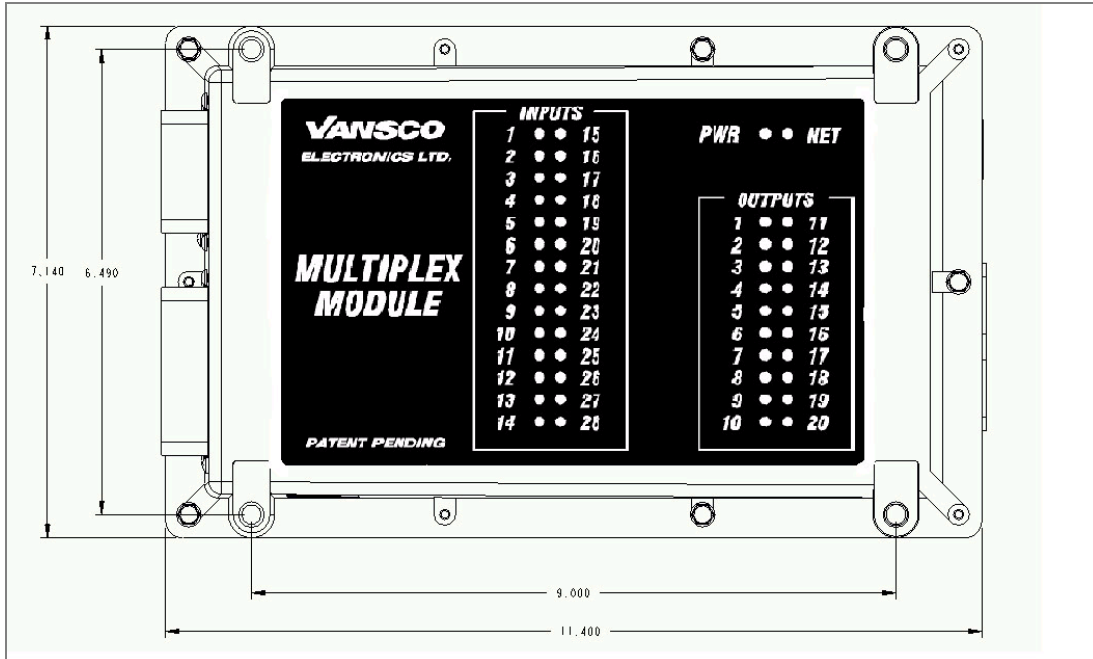

Top view of VMM2820

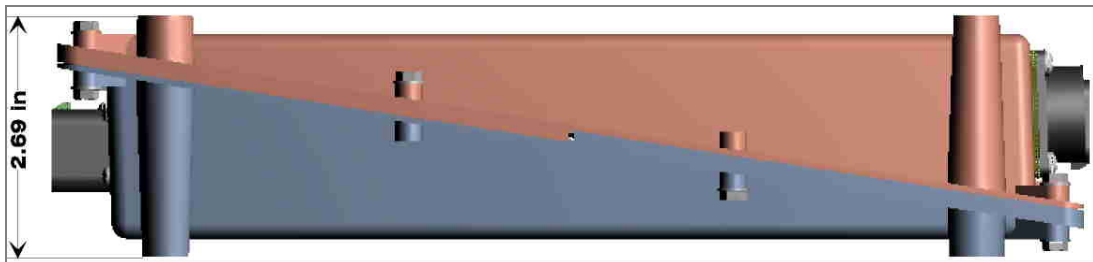

Side view of VMM2820



## 3. VMM Hardware

---

This section will discuss the various features of the VMM hardware including a description of inputs, outputs, communications, addressing, and diagnostic LEDs.

### 3.1. VMM Inputs

There are two types of inputs on each VMM: digital inputs and analog inputs. Digital inputs read signals with either high or low value (that is, battery voltage or ground). Digital inputs are typically connected to vehicle signals that have two states. These include rocker switches, toggle switches, or ON/OFF signals from other vehicle electronic control modules (ECMs). Analog inputs read signals with voltage values between 0 volts and 32 volts. They are typically connected to vehicle signals that could have a continuous range of values between ground and 32 volts. These include signals like air pressure sensors, fuel level sensors, and battery voltages.

The following table shows the inputs available on each VMM:

Input Number	Input Type	Power Save Control
Digital 1 to 5	Switch-to-ground	Yes
Digital 6 to 10	Programmable: switch-to-ground or switch-to-battery	No
Digital 11 to 28	Switch-to-ground	No
Analog 1	0 V to 32 V	No
Analog 2	0 V to 32 V	No
Analog 3	0 V to 32 V	No
Vbat Analog	Internally connected to VMM power input	No

Digital inputs 1 to 5 and 11 to 28 can be connected to any signal that is considered active when at ground potential. Digital inputs 6 to 10 can be connected to any signals that are considered active when they are at ground potential or at battery potential. The user programs these as either switch-to-battery or switch-to-ground depending on which type of signal they are connected to.

Digital inputs 1 to 5 also control VMM Power Save Mode. If any of these five inputs are active (ground potential) then the VMM will power up and begin normal operation. If all of these five inputs are inactive (floating or at battery potential), then the VMM will power down to Power Save Mode. When the VMM is in Power Save Mode, all power is disconnected from the microprocessor and logic circuits inside the unit. This minimizes drain on the vehicle battery.



**Warning:** VMM inputs are not to be connected directly to inductive loads such as solenoid or relay coils which can produce high voltage spikes. If an input is connected to an inductive load, then a protective diode must be used to prevent damage to the VMM input circuit.

---

## 3.2. VMM Outputs

There are two types of output on each VMM, high side outputs and bidirectional outputs. High side outputs switch battery voltage to output pins. Bidirectional outputs act like single pole single throw (SPST) relays; when they are active they connect two points.

High side outputs are typically used to drive power to vehicle loads such as bulbs, motors, solenoids, and switch-to-battery signal inputs on other ECMs. They require a voltage or a ground on either of their pins in order to operate.

Bidirectional outputs are typically used to connect ground to vehicle loads such as bulbs, motors, solenoids, and switch-to-ground signal inputs on other ECMs. This typical bidirectional use is called a low side driver, but the bidirectional switches are not limited to this function. They can be arranged as high side or low side, or simply as a method of connecting two points. They do not require a voltage or a ground on either of their pins in order to operate.

Several vehicles on the market today have electrical systems containing two batteries connected in series. This arrangement provides two voltage potentials in the vehicle, 12 V (regulated to 14 V) and 24 V (regulated to 28 V) for driving several different types of loads. For this reason the high side outputs are arranged so that they are connected to two different “bus bars” in the VMM. Half the high side outputs are connected to bus bar 1 and the other half are connected to bus bar 2. Each VMM has two external power pins, one connects to bus bar 1 and the other connects to bus bar 2. This allows a single VMM to switch either 12 V, 24 V, or both.

The following table lists outputs available on each VMM:

Output Number	Output Type	Max Continuous Current	Connected to Bus Bar (1 or 2)	Allowable Load Type
1 to 9	High Side	6 A	Bus Bar 1	Resistive, Bulb, Inductive, Motor
10 to 18	High Side	6 A	Bus Bar 2	Resistive, Bulb, Inductive, Motor
19 to 20	Bidirectional	4 A	N/A	Resistive, Bulb, Inductive <sup>1</sup> , Motor

Outputs 1 to 18 have a maximum continuous current rating of 6 amps, which means that a load of approximately 2.3 ohms can be connected to each output if each is supplying 14 V (4.6 ohms if each output is supplying 28 V). Outputs 19 and 20 are the two bidirectional outputs supplied with the VMM. They have a maximum continuous current rating of 4 amps which means that a load of approximately 3.5 ohms can be connected to each output if each is supplying 14 V (7 ohms at 28 V).

Outputs 1 to 16 can be Pulse Width Modulated (PWM). This allows them to send out a 100 Hz square wave with an On to Off duty cycle ratio of 0% to 100%.

All outputs are protected against short circuits, over currents, and reverse battery. High side outputs can handle inrush currents of approximately 42 A for a period of one second. Inrush currents of a higher value must drop below the 42 A point within approximately 0.5 ms.

### 3.3. VMM Communications

The VMM has one communication port for use in a multiplex system environment. This communication port is a Controller Area Network (CAN) type.

CAN is a high speed serial communication network which allows up to 32 nodes or CAN based ECMs to be connected at any given time. The VMM CAN conforms to SAE J1939 standards, which makes it a standard device that can be used without conflict with other CAN J1939 based equipment. The VMM CAN operates at a bit rate of 250 kbps (kilobits per second) which is more than 26 times faster than the industry standard SAE J1708 communication bus.

The VMM CAN is the multiplex system backbone. It is the communication cable through which all system inputs and outputs are multiplexed. Each VMM has a CAN port which, when connected in a two-or-more module system, creates a CAN communication bus.

<sup>1</sup> Inductive and motor loads on the bidirectional switches require the use of external back EMF diodes or snubber circuits.

The following information is currently communicated on the VMM CAN communication bus:

CAN Message Type	CAN Data
VMM I/O	Input, Output, Flag, Timer and Fault states for all I/O on a single VMM.
VMM Analog Inputs	Analog values for three analog inputs on a single VMM.
VMM Telltale Outputs	Output states for two telltale clusters.
Other J1939 messages	Any J1939 defined message

The CAN communication bus can be linked to other vehicle networks such as SAE J1708 or SAE J1850 through “gateway” devices. The gateway would contain filtering information allowing only user-defined messages to pass from one network type to the other. Using a gateway device allows SAE J1708 based engine, ABS and transmission controllers to communicate with the VMMs in a multiplexed system. Critical information such as vehicle speed, gear position or diagnostics can be communicated to VMMs and certain outputs can be activated or deactivated accordingly (using the vehicle configuration ladder logic).

The VMM CAN is the link to VMM programming and VMM diagnostics. Each VMM in a multiplex system can be programmed and/or queried for diagnostics from a single CAN diagnostics port located on a vehicle. The CAN diagnostics port is simply a connector, which taps into the CAN shielded twisted pair cable.

### 3.4. VMM Addressing

Each VMM is exactly the same as all other VMMs in a multiplex system. That is, each VMM has exactly the same hardware configuration (28 digital inputs, 3 analog inputs, 1 CAN port, 18 high side outputs and 2 bidirectional outputs) and each VMM is programmed with exactly the same firmware configuration. Since each VMM is exactly the same, a method is required to tell them which tasks to perform. This is accomplished through addressing.

VMM systems require a unique address to be hard wired into the vehicle wire harness. The addresses are additional VMM switch to ground digital inputs reserved for addressing purposes only. These address inputs are located on the VMM input connector. There are five address inputs on each VMM, each one representing an individual address binary digit (bit). With a five bit address the system can contain a maximum of 32 distinct addresses (see table below).

Address Input Number					VMM Address
1	2	3	4	5	
0	0	0	0	0	VMM 1
1	0	0	0	0	VMM 2

Address Input Number					VMM Address
1	2	3	4	5	
0	1	0	0	0	VMM 3
1	1	0	0	0	VMM 4
0	0	1	0	0	VMM 5
1	1	1	1	1	VMM 32

The address representing VMM 32 is reserved for diagnostic purposes, which means that there are only 31 addresses available for a VMM system. Note that in the table above, 0 represents inactive (no wire connected) and 1 represents active (wire connected to the pin and to ground).

As stated above, the firmware in each module is exactly the same. This means that each module contains the full vehicle configuration ladder logic. Each VMM selects which section of the ladder logic to run depending on the physical wire harness address. This feature allows VMMs to be interchanged without affecting the vehicle operation. This can be done without reprogramming or setting dip switches. Simply pop, swap, and go!

### 3.5. VMM Diagnostic LEDs

The VMM has two main diagnostic features. One is driven on the CAN communication bus and requires Vansco VMM Software to operate. The second is diagnostic LEDs located on the front of each VMM. The latter will be discussed in this section.

Each VMM has 28 digital inputs, 20 outputs, and a CAN port. Each VMM also has 28 LEDs representing active digital inputs: 20 LEDs represent active outputs, one LED represents CAN activity and one represents overall module power/health.

The 28 input LEDs have two states: ON and OFF.

- If an input LED is ON, the corresponding input that the LED represents is Active.
- If an input LED is OFF, the corresponding input that the LED represents is Inactive.

The 20 output LEDs have three states: ON, OFF, and FLASHING.

- If an output LED is ON, the corresponding output that the LED represents is Active.
- If an output LED is OFF, the corresponding output that the LED represents is Inactive.

- If an output LED is FLASHING, the corresponding output that the LED represents is faulted. There are five types of faults that will cause output LEDs 1 to 18 to flash. These are short circuit, over current, back drive, no power detected at the output pin, and open circuit. There are two types of faults that will cause output LEDs 19 and 20 to flash. These are short circuit and over current.
  - A short circuit fault occurs when the circuit that a VMM output is driving shorts to ground. An over current fault occurs when the circuit that a VMM output is driving is drawing excessive current. A back drive fault occurs when the circuit that a VMM output is driving is shorted to battery voltage. A no-power-detected fault occurs if an output circuit is physically damaged or if there is no power on the output bus bars. An open circuit fault occurs if open load detection is turned on (via ladder logic) and there is no load attached to the output.



**Note:** A back drive and open circuit fault is detected when an output is in the off state and the short circuit/over current/no power faults are detected when the output is in the on state.

---

The power LED has three states, ON, OFF, and FLASHING.

- If the LED is ON, the module is powered up and is operating normally.
- If the power LED is OFF, the module is either in Power Save Mode or the vehicle power has been completely disconnected.
- If the LED is FLASHING, the module is powered up but currently has no vehicle configuration loaded into it or there is an internal VMM fault.

The diagnostic LEDs are designed to simplify vehicle debugging. Each LED represents an input or output and as such, each LED is essentially a circuit continuity tester. An indication of an electrical fault condition on a diagnostic LED should be investigated and corrected immediately to prevent system damage.

## 4. VMM Operation

---

The VMM performs many tasks at the same time. Each VMM must be able to read inputs, switch outputs, monitor outputs for fault protection, communicate VMM information on the CAN, and control VMM LED diagnostics, vehicle ladder logic programming, VMM “plug and play” automatic vehicle configuration programming, and CAN diagnostics. This section is a brief overview of VMM operation and how these tasks are performed.

### 4.1. Reading Inputs

The VMM reads all 28 digital inputs and the three analog inputs at a rate of 40 Hz (40 times per second). All readings are stored in memory as the most recent state, which is then used for same module output control and for communicating onto the CAN.

### 4.2. Switching Outputs

The VMM switches outputs according to the vehicle configuration ladder logic. Outputs are refreshed at the same rate as the inputs are read (40 times per second). Outputs 1 to 16 can be Pulse Width Modulated at a rate of 100 Hz, from 0% to 100% modulation. PWM is used to control the average power from the VMM outputs. This is typically used to control light intensity or DC motor speed.

### 4.3. Output Fault Monitoring

The VMM detects five types of output faults: short circuits, over currents, back driven outputs, no power on the output pins and open loads. Electrical fault conditions are detectable in ladder logic and system response to faults can be programmed by the system/vehicle designer based on reported faults.

- The short circuit protection is performed by hardware circuitry to ensure high-speed operation. The hardware informs the VMM microprocessor that a

short circuit has occurred. When this fault is detected, the VMM reports the fault via a fault flag for use in ladder logic.

- Over current, back driven and no power on the output pins are detected using the VMM microprocessor, which continuously monitors current flow through the output switch and voltage level at the output pin. Microprocessor fault monitoring occurs at a rate of 40 Hz (40 times per second). When this fault is detected the VMM reports the fault via a fault flag for use in ladder logic and starts the VMM fault response algorithm.
- Open load detection is performed by applying a brief low current pulse to all the output pins on a module. The resulting voltage read back from the output pin is analyzed to determine if there is a load attached. When this fault is detected the VMM reports the fault via a fault flag for use in ladder logic and starts the VMM fault response algorithm.
- Outputs 19 and 20 can detect short circuit and over current faults only. There is no back driven, no power or open loads detected on these two outputs. When this fault is detected the VMM reports the fault via a fault flag for use in ladder logic.

The fault functions above may have additional programmable options associated with them, for more information please see the VMM Software User Guide or the VMM Software help file available with your copy of the VMM software.



**Caution:** It is the responsibility of the system/vehicle designer to ensure that the electrical system faults are reported to system/vehicle operators so the faults can be corrected by service personnel. Faults should not be left uncorrected. Failure to follow this recommendation could lead to damage of the VMM.

---

## 4.4. CAN Communications

Each VMM is designed to communicate input/output state information on the CAN at a maximum rate of 40 Hz (40 times per second). CAN communication occurs whenever there is a state change on an input (analog or digital), output, flag, or timer. If none of these items changes state for a period longer than one second, the VMMs automatically transmit their I/O status every second. This acts as a “heart beat” to tell if any VMMs in the system are not operating.

## 4.5. LED Diagnostics

The VMM is designed to update the diagnostic input/output status LEDs at a rate of 40 Hz (40 times per second).



## 4.6. Vehicle Configuration Ladder Logic Programming

All VMMs in a system can be programmed with new vehicle configuration ladder logic from a single CAN diagnostic port located in the vehicle. This is accomplished with a Vansco Data Link Adapter (DLA) or a Vansco Pocket Gateway Module (PGM) and a standard desktop or laptop PC loaded with VMM Software. The DLA or PGM provides a link from the CAN to the PC RS-232 serial port. VMM Software provides the tools to create, modify, and download the ladder logic from the PC to the VMMs in a vehicle.



**Note:** The VMM Software and its uses are discussed in detail in the VMM Software User Guide.

---

When downloading begins, all VMMs are taken offline (all outputs are turned off, driving of diagnostic LEDs is discontinued, and power LEDs begin flashing at a slow rate). To increase downloading speed, vehicle configuration is downloaded to all VMMs in the system simultaneously. Once the new vehicle configuration ladder logic has been downloaded, the modules will come back online automatically.



**Caution:** When re-programming a VMM system, all VMM outputs turn off, which could result in vehicle movement or vehicle implement movement. Ensure that all safety equipment for your vehicle is used and all persons are away from the vehicle prior to initiation of programming.

---

## 4.7. Plug and Play Automatic Module Programming

The VMM has a very powerful Plug and Play feature, which allows replacing a single module in a vehicle system with a VMM that contains a different vehicle configuration or no vehicle configuration at all. There is no need for reprogramming. Upon every system power up each VMM communicates its firmware and ladder logic revision on the CAN. If one module mismatches the majority, that one module automatically downloads the firmware and ladder logic from another VMM in the system. Once this process is complete, all modules go online and continue to operate as though no module was changed.

This feature is particularly useful for module changes in the field in the unlikely event that a module in a system fails to operate properly.



**Caution:** When plug and play is initiated on a VMM system, all VMM outputs turn off, which could result in vehicle movement or vehicle

implement movement. Ensure that all safety equipment for your vehicle is used and all persons are away from the vehicle prior to initiation of plug and play.

---

## 4.8. CAN Diagnostics

The VMM is capable of logging errors in non-volatile memory, which can later be retrieved for analysis by service personnel. Items that are logged include output faults, CAN failures, user selectable event counters, timers, and generic number logs.

VMMs automatically log output faults and CAN failures. The user cannot customize this function. Output faults and CAN failures are logged once per event, however only the time (in module running hours) is logged for the last event. For example, if a short circuit occurs on output 1, the event is logged and the hour (in module running hours) is recorded. If the short recurs on output 1 before service personnel have cleared the log, the time recorded for the first fault will be over written by the second fault. The total number of occurrences of the event since the logs were last cleared will be recorded for each event.

User selected event counters, timers and generic logs are custom features of VMMs. They are set in the VMM Software when ladder logic is created. Event counters allow the user to set up a log for a specific event (for example, door solenoid activation) and count whenever this event occurs. Similarly, event timers can count duration of an event in increments of hundredths of seconds (0.1s intervals). The generic logs allow storage of generic numbers, accurate to one decimal place. These log types are set up in the ladder logic for the vehicle in the same way that outputs are defined. The VMM Software User Guide or the VMM Software help file provides more information about this.

All logs can be retrieved and cleared using the VMM Software application. This application also allows real time viewing of system logic operations, and it allows inputs and outputs to be forced to active/inactive states regardless of what the input/output is supposed to be doing. This is convenient for vehicle logic debugging but should be used with caution. Duration, counter, and generic logs can all be reset to zero (or any other value) dynamically within ladder logic. Module fault logs cannot.

## 5. VMM Setup and Use

---

This section reviews common practices that should be used when developing a vehicle electrical system that uses VMMs.

### 5.1. Input Considerations

As discussed in Section 3, there are four different types of inputs available on the VMM. To recap, these are

- Digital switch-to-ground type
- Digital switch-to-battery type (programmable)
- Digital switch-to-ground type with power control
- Analog type

When designing the wire harness for a vehicle the main input item that has to be considered is the “Digital switch-to-ground type with power control” or simply “Power Control Inputs”. These are inputs 1 to 5 and they behave like any other switch-to-ground input on the unit except that they control the power to the VMM. This means that at least one of these inputs must be active (or grounded) in order to power up a VMM in the vehicle.

In addition, input 1 on all the VMMs in a vehicle is reserved to be “Master Power”. This is a reference input that the VMM uses to perform additional tasks. Input 1 on all VMMs in a system must be connected to the same source, which means that when this source is active all VMMs in the vehicle will be powered on. Typically this source would be a dashboard switch called “Master Power” or the “auxiliary”/“run” position of a key switch. When this “Master Power” input is active the following tasks are performed by the VMM:

- Plug and Play system check
- VMM Communication failure check

VMM Communication Failure and Plug and Play checks require that all VMMs defined in the system are powered when the check occurs. The only way to

ensure that all VMMs are active in a system is to dedicate a single input to represent all VMMs “online”. Thus input 1 on all VMMs is dedicated to “Master Power” for the system.



**Note:** You must ensure that input 1 on each module in a system is dedicated as a “master power” input if you want plug and play and network fault detection functionality.

---

Inputs 2 to 5 are general-purpose power control inputs in that the VMMs don’t have to be connected to the same source. Power control inputs are designed to allow power up of only those VMMs required to perform a function. For example, hazard flashers may require one VMM at the front of the vehicle for front and side turn lamps and one VMM at the rear for rear turn lamps. Only two VMMs need to be powered up to perform the hazard function. In this example, the hazard switch on the dashboard could be run to one of the general-purpose power control inputs (2 to 5) on the two VMMs in use. When the hazard switch is turned on only these two VMMs will be active (provided no other power control inputs are currently active on other VMMs). This minimizes power consumption for hazard operation, and extends the length of time that they will operate on the vehicle battery.

Another consideration is whether any of the inputs being sent to VMMs are considered active when connected to battery or to ground. In most applications, there are very few switch-to-battery type inputs, which is why the VMM allows only a maximum of 5 of this type of input. If the vehicle application has a switch-to-battery input, it should be sent to one of inputs 6 to 10, which can be programmed as switch-to-battery type using the VMM Software application.

There are no other specific considerations regarding vehicle digital inputs. VMM inputs 11 to 28 are all switch-to-ground type and there are no special functions associated with any of these inputs.

Analog inputs can handle a voltage-type or resistive-type input from various sensors on the vehicle. The ground reference for these analog inputs is the ground pins on the VMM input connector (see Section 6 for pin outs). The maximum allowable voltage on any of the analog input pins is 32 V and the minimum is 0 V. Any voltage above 32 V will be internally clamped to 32 V.

## 5.2. Address Considerations

There are five address inputs into each VMM in a system. These inputs are similar to the switch-to-ground digital inputs but are dedicated to VMM addressing. These inputs have to be grounded or left floating according to the table shown in section 3.4. A reminder: the VMM Software application will show

the user a pin out of each VMM in the system so the address lines to connect to ground for each VMM are known. There are no special considerations for these inputs.

## 5.3. Output Considerations

As discussed in section 3.2 there are two types of VMM outputs, these are:

- High side outputs
- Bidirectional outputs

To connect to the high side outputs two VMM connections have to be made. First, the bus bar power pin for the output in question must be connected to the battery voltage that is to be switched (see Section 6 for VMM pin outs). Second, the output in question must be connected to one side of the load and the other side of the load to vehicle ground. When the output turns on, it switches the voltage on the bus bar power pin to the output pin, which is connected to the vehicle load.

High side outputs must not draw more than 6 A per output, 30 A per bus bar (9 switches per bus bar) or 60 A per VMM (2 bus bars per VMM). These current ratings are for continuous operation so loads which add up to more than 30 A per bus bar or 60 A per VMM can be connected, provided all loads are not operating at the same time.

Bi-directional outputs act like single-pole single-throw relays. Each bi-directional output is associated with two pins (pin A and pin B). When the output is activated, pin A makes contact with pin B. Pin A and pin B of each of these two outputs can be connected in any manner. For example, to connect output 19 as a low side driver, simply connect output 19A to ground and connect output 19B to the load to be driven (the other side of the load should then be connected to the battery voltage of choice). This connection could be reversed as well; output 19B could be connected to ground while output 19A is connected to the load. In this manner, these outputs can be used either to switch high side or low side loads, or to switch battery- or ground-to-signal inputs on other electronic control modules in the vehicle (engine or transmission controller for example).

For a complete list of voltage and current limitations on the VMM outputs, refer to section 6.



**Caution:** When using bi-directional switches you must ensure that the highest voltage being switched is less than or equal to the voltage being supplied to the VMM's logic power input (pins J1-24, J1-25 and J1-26).

---



**Caution:** It is the responsibility of the system/vehicle designer to ensure that the electrical system faults are reported to system/vehicle operators so the faults can be corrected by service personnel. Faults should not be left uncorrected. Failure to follow this recommendation could lead to damage of the VMM.

---

## 5.4. Power Considerations

VMMs have internal short circuit and over current protection. In extreme short circuit situations, voltage will dip on the power wire supplying the short circuit current. This is due to the inductance inherent in all wiring. To ensure maximum possible short circuit protection on the VMM product, low current power wiring should be isolated as much as possible from high current wiring. The logic power input (connector pins J1-24, 25 and 26) and the logic ground input (connector pins J1-27, 28, 29 and 30) on the VMM2820 are considered low current draw loads. The bus bar power input (connector pins J4-1 and 2) on the VMM2820 are considered high current draw loads. The bus bar power pins are subject to short circuit currents for brief periods of time and should therefore be isolated from the logic power pins. This isolation prevents dips in voltage on the bus bar wires from affecting the power supplied to the logic of the VMM2820. This isolation scheme is shown in the following diagrams.

All power wires coming from battery or the alternator terminals require fusing to protect the wiring in the event of a short circuit between the power source and the VMM2820. A fuse value of 40 A or less is recommended on each VMM2820 bus bar wire.



**Note:** Proper fusing is required on any power wire coming off the vehicle's battery or alternator terminals. This fusing is not shown in the diagrams below.

---

### 5.4.1. Cable Grounded System

The cable grounded system is a system where by ground is supplied to the various loads and modules in the vehicle by means of large gauge wires or cables. The following diagram shows how the power and ground should be connected in the vehicle.

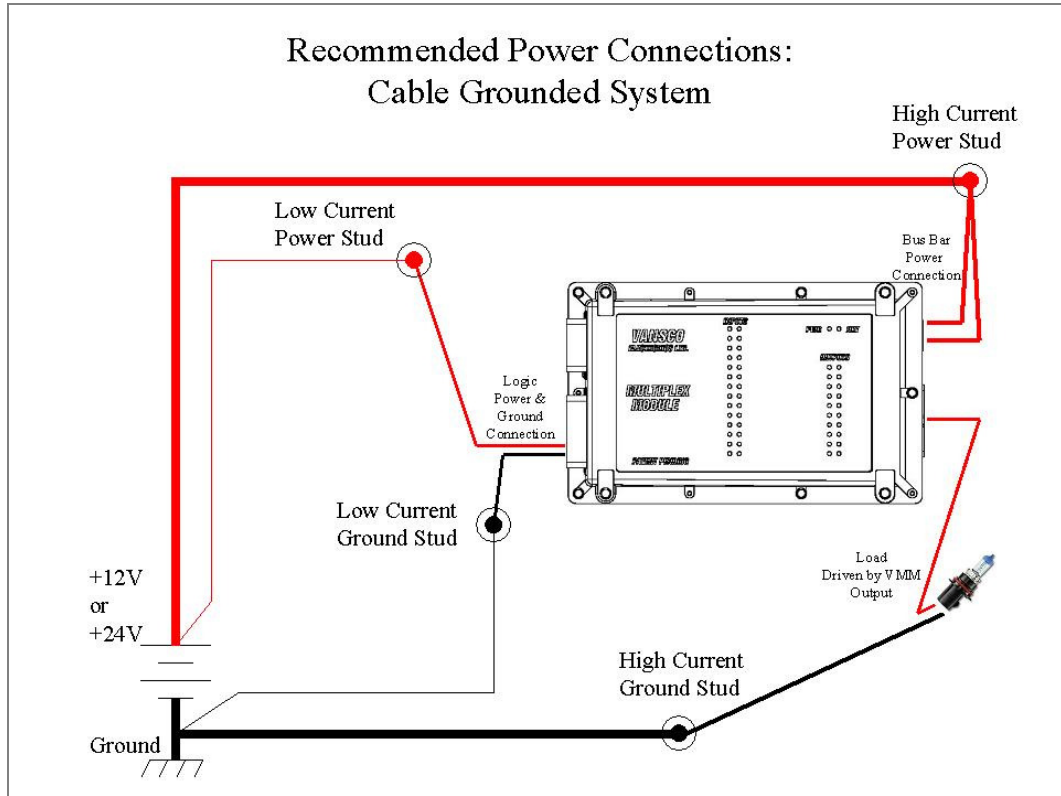

**Cable grounded system**

### 5.4.2. Chassis Grounded System

The chassis grounded system is a system where by ground is supplied to the various loads and modules in the vehicle by means of the vehicle's metal chassis. The following diagram shows how the power and ground should be connected in the vehicle.



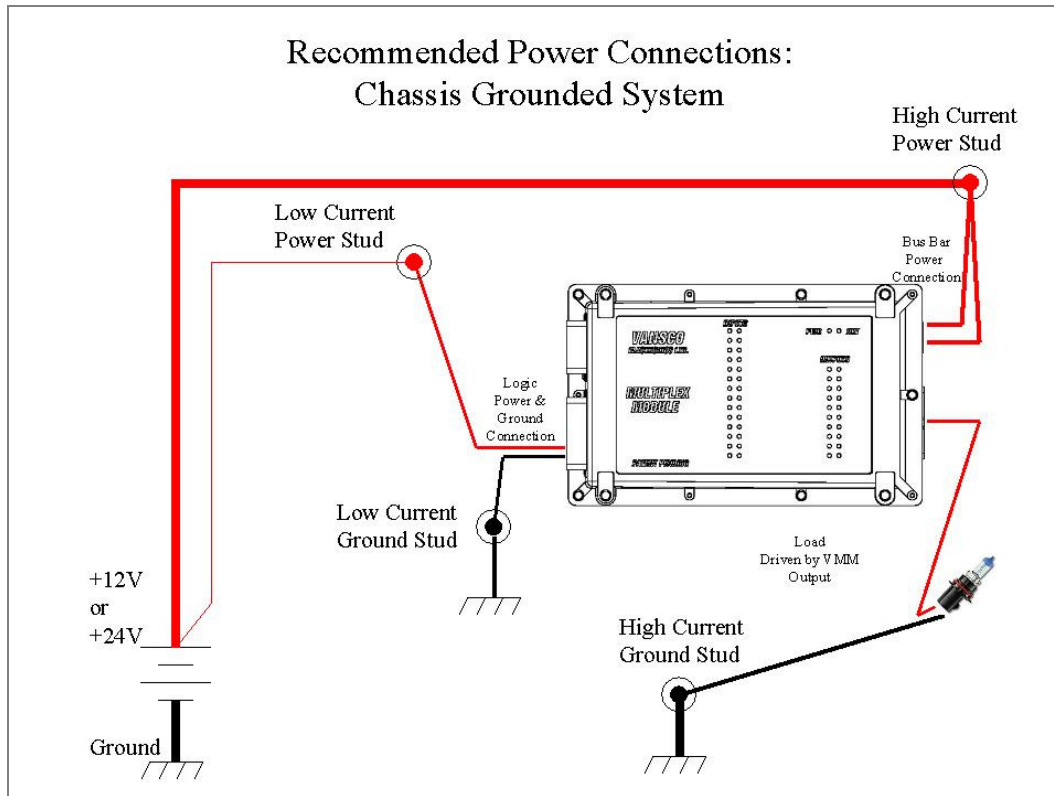

**Chassis grounded system**

There are situations where both cable and chassis grounded systems occur on the same vehicle. For example, low current ground wires could be run from the modules to the battery stud in a chassis ground system. This would ensure that ground rises due to current flow in the chassis under heavy load conditions do not affect logic ground on the module.

Maintaining isolation between low current ground and high current ground is also beneficial for ensuring proper input detection, particularly with analog inputs. The VMM2820 uses the voltage value at the logic ground pins as the reference for analog inputs. If an analog value is connected to one of the VMM2820's analog inputs, the voltage that the VMM2820 sees is with respect to the logic ground pins. If there is a difference in voltage between the sensor ground and the VMM2820 logic ground, that voltage difference will appear on the analog input reading giving an erroneous value of the actual sensor voltage. Voltage differences between sensors and the VMM2820 grounds can be minimized by ensuring that these grounds are isolated from power grounds.



**Note:** Isolating low current ground and power from high current ground and power in a system is essential for maintaining signal integrity.



## 5.5. Communication Considerations

VMMs operate on SAE J1939 networks, which interconnect all VMMs (and other optional equipment). The physical cable for the J1939 network has three wires (J1939+, J1939- and J1939 Shield) and should be connected to the VMM input side (see VMM pin outs in Section 6).

SAE J1939-11 calls for a main “back bone” cable, no longer than 40 metres, with 120-ohm terminators on each end. Nodes (such as VMMs) are connected to the “back bone” using wire stubs no longer than 1 metre. Stubs in the J1939 network should all be different lengths to reduce the possibility of standing wave interference on the network. All J1939 connections should be done using SAE J1939 specified connector types and cable types. At one location on the “back bone”, the cable shield wire should be securely connected to vehicle chassis ground to ensure adequate shielding on the network.

The connectors used on the J1939 network (that is, connecting stubs and terminators to the back bone) consist of three pins of “T” or “Y” configuration which allow branching off of the back bone. There are two manufacturers of J1939 connectors recognized by SAE: ITT Cannon and Deutsch. Both manufacturers offer terminator connectors with a 120-ohm resistor built in, but the ITT Cannon connectors have the advantage of easier terminator connections directly into the “Y” connector and fewer parts required (no secondary locks). An example J1939 network arrangement with manufacturer part numbers is shown below.

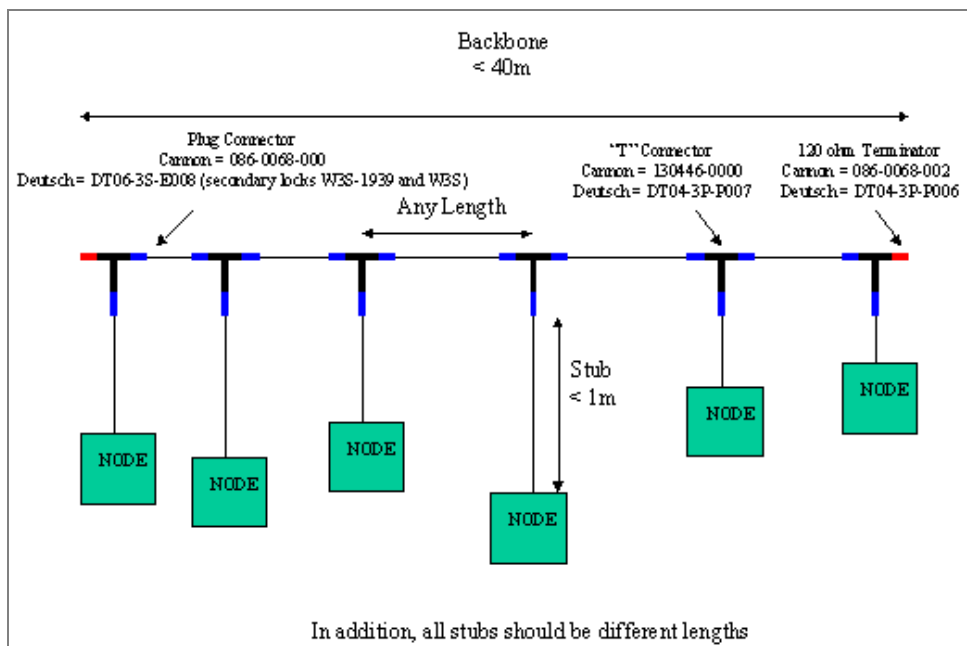

**CAN connections**

For a complete list of J1939 connection considerations, please refer to the SAE J1939 specifications available through the Society for Automotive Engineers. SAE J1939-11 covers the physical aspects of the network including cable type, connector type, cable lengths, etc.

## 5.6. General Considerations

VMMs were designed to reduce vehicle wiring, improve vehicle diagnostics and simplify maintenance. The following suggestions can be used to take full advantage of the power of the VMM system:

- Place VMMs in locations close to inputs and outputs to minimize wire lengths in the vehicle harness.
- Send as many inputs and outputs as possible to VMMs (i.e., “multiplex” as much as possible) to maximize diagnostic capability and simplify vehicle configuration changes. Inputs and outputs going to VMMs can be diagnosed electronically using the VMM Software package and the VMM LEDs. These inputs and outputs can also be configured through ladder logic to perform specific operations. If modifications are required in the future, a ladder logic change is usually all that is needed to implement it on vehicles in the field.
- Installing junction boxes at certain locations in the vehicle can minimize the number of heavy gauge power cables routed throughout the vehicle. VMMs can be located in the junction boxes and can then be connected to the main vehicle harness through “bulkhead” connectors. This also separates the junction box harnesses from the main harness and allows for easier modifications to the vehicle harness if required.
- The VMMs in a system must have all connectors disconnected prior to initiating welding at any location in the system.
- The vehicle design should provide a means of reporting electrical faults (short circuit, over current, etc) to a vehicle operator to ensure electrical system faults are found and repaired by vehicle service personnel. One method of providing this indication is by using the VMM telltale output messages to drive the vehicle dash board telltales.



**Caution:** Welding can cause potential damage to VMM products installed in a vehicle or system. All electrical connections should be disconnected from all VMMs in a vehicle or system prior to welding on the vehicle or system.

---

Multiplexing a vehicle helps not only to reduce harnessing costs and vehicle weight, but it also reduces vehicle-troubleshooting time. This can reduce costs at both the vehicle manufacturer and in the field.

## 6. VMM Specifications

---

### 6.1. Electrical/Environmental

#### General

	MIN	NOM	MAX	UNIT
Operating Voltage (Logic)	6	28	32	V
Operating Voltage (High Side Busbar 1 and 2)	6	28	32	V
Operating Over Voltage (Logic and outputs)	-	48	-	V
Operating Current Draw (Power Pin) <sup>2</sup>	-	120	-	mA
Operating Current per input cct <sup>3</sup>	-	8.5	-	mA
Operating Current Draw (Power Save) <sup>4</sup>	-	-	20	mA
Output Current per bus bar	-	-	30	A
Recommended Fuse per bus bar	-	-	40	A
Output Current per module	-	-	60	A
Operating Temperature	-40	-	+85	°C
Storage Temperature	-55	-	+125	°C

#### Inputs (+25°C unless otherwise stated)

	MIN	NOM	MAX	UNIT
# Active Low Digital Inputs	-	18	-	-
# Programmable Active High/Low Digital Inputs	-	5	-	-
# Active Low Power Save Digital Inputs	-	5	-	-
# Analog Inputs	-	4	-	-
Voltage on Input pin <sup>5</sup>	0	-	32	V
Active low activate voltage	-	-	2.8	V

<sup>2</sup> Assumes 28 V power with only one input active (one power save input must be active to power device).

<sup>3</sup> Assumes 28 V power, and input circuit active low, and input pin grounded.

<sup>4</sup> Assumes 28 V power, no active high inputs in use. If active high inputs are in use, an additional x/1 kohm (amps) must be added per output (where x is the voltage level of the active high input).

<sup>5</sup> Inputs also protected against 48 V over voltage, ESD transients (SAE J1455) and reverse battery connection (SAE J1455).

	MIN	NOM	MAX	UNIT
Active low deactivate voltage	5	-	-	V
Active low hysteresis	-	2.2	-	V
Active high activate voltage	5	-	-	V
Active high deactivate voltage	-	-	2.8	V
Active high hysteresis	-	2.2	-	V
Analog input type	-	Voltage	-	-
Analog input resolution	-	0.1	-	V
Analog input error with 14 V input voltage	0	-	0.13	V
Analog input error with 32 V input voltage	0	-	0.21	V

### Outputs (+25°C unless otherwise stated)

	MIN	NOM	MAX	UNIT
# High Side Outputs Total	-	18	-	-
# High Side Outputs on Busbar 1	-	9	-	-
# High Side Outputs on Busbar 2	-	9	-	-
# Bidirectional Outputs	-	2	-	-
High Side Voltage <sup>6</sup>	6	-	32	V
Bidirectional Voltage <sup>22,7</sup>	6	-	32	V
High Side Current per output	0	-	6	A
Bidirectional Current per output	0	-	4	A
High Side short cct trip point <sup>8</sup>	-	42	-	A
Bidirectional short cct trip point	-	20	-	A
Short cct trip time (high side outputs)	-	-	5	ms
Short cct trip time (bi-directional outputs)	-	-	0.5	ms
High Side over current trip	-	-	10	A
Bidirectional over current trip	-	-	6	A
Over current trip time	-	-	1	s
Fault reset time	5	10	-	s
High Side reverse battery protection <sup>9</sup>	-	-	48	V
Bidirectional reverse battery protection	-	-	48	V

### Memory

	MIN	NOM	MAX	UNIT
Ladder Logic Memory (flash) <sup>10</sup>	-	128k	-	byte

<sup>6</sup> Outputs protected against 48 V over voltage (SAE J1455).

<sup>7</sup> Bi-Directional Outputs must not switch voltages that are greater than the voltage applied to the logic power input pin of the VMM2820 (voltage readings referenced to VMM logic ground).

<sup>8</sup> Outputs protected against short circuits to ground and power (designed to meet ASAE EP455).

<sup>9</sup> Reverse battery protection turns all high side outputs ON. In this state short circuit and over current protection is not operational.

	MIN	NOM	MAX	UNIT
Number of Count/Time Logs	-	8	-	-
Count/Time Log Size	-	2	-	byte
Fault Log Size	-	4k	-	byte

## 6.2. Design Verification Standards

The test descriptions below are based on Environmental Specification SAE J1455 Aug 94 and ANSI/ASAE EP455 Jul 91. For full test descriptions, refer to these specification documents available through the Society for Automotive Engineers (SAE) and the American Society of Agricultural and Biological Engineers (ASAE). Deviations from official specification are shown in the test description column. The **Grp** column defines which group of test subjects were exposed to the test. The design verification testing included 5 groups with 4 UUTs per group. Thermal tests, also referred to as conditioning tests are always performed before all other tests. The order shown in the table for all tests other than thermal tests is not necessarily the order in which test tests were performed on the test subjects.

### Design Verification Test Descriptions

Grp	Test Name Test Spec	Test Description	Deviate Y/N	Pass /Fail	Comments
A B C D E	Storage Temperature  (Non- Operational)  EP455 Jul91 Section 5.1.2 Level 1	<ol style="list-style-type: none"> <li>1. Place the UUT in a chamber and set the temperature from +25°C to -55°C.</li> <li>2. Allow the UUT to remain at -55°C for 4 hours.</li> <li>3. Set the chamber temperature to +125°C.</li> <li>4. Allow the UUT to remain at +125°C for 4 hours.</li> <li>5. Set the chamber temperature to +25°C.</li> </ol> <ul style="list-style-type: none"> <li>• Test for impaired function at room temperature.</li> <li>• Temperature transition must be at an average rate of less than 0.5°C/minute.</li> <li>• See supporting record for further test details.</li> </ul>	No	Pass	

<sup>10</sup> As a reference, a typical vehicle application using 6 VMMs and 160 ladder logic rungs takes up 10% of available ladder logic memory.

Grp	Test Name Test Spec	Test Description	Deviate Y/N	Pass /Fail	Comments
A B C D E	Temperature Cycle (Operational)  J-1455 Aug94 Section 4.1.3.1 Fig. 2A, Page 7.	<ol style="list-style-type: none"> <li>1. Attach test loads and apply 12 VDC power to the UUT in the chamber.</li> <li>2. Set the chamber temperature from +25 °C to -40°C.</li> <li>3. Maintain -40°C temperature for a duration of 3.5 hours</li> <li>4. Set the chamber temperature from -40°C to +85°C.</li> <li>5. Maintain +85°C temperature for a duration of 11 hours</li> <li>6. Set the chamber temperature from +85 °C to +25 °C.</li> <li>7. Maintain +25°C temperature for a duration of 8 hours</li> <li>8. Repeat steps 2 – 7 twice.                             <ul style="list-style-type: none"> <li>• Temperature transition rate must be 3°C/minute ±1.5°C.</li> <li>• Test for impaired function at hot and cold extremes</li> <li>• Allow the temperature to stabilize for 20 minutes before subjecting the UUT to functional tests.</li> <li>• See supporting record for further test details.</li> </ul> </li> </ol>	No	Pass	
A B C D E	Thermal Shock (Non-Operational)  J-1455 Aug94 Section 4.1.3.2 Fig. C, Page 8.	<ol style="list-style-type: none"> <li>1. Place the UUT in a chamber with temperature set to -40°C.</li> <li>2. Allow the UUT to remain at -40 °C for duration of 2 hours before transferring it to another chamber with temperature set at +85°C.</li> <li>3. Allow the UUT to remain at +85°C for a duration of 2 hours before transferring it back to the other chamber with temperature set at -40°C.</li> <li>4. Repeat steps 2 and 3 five times.                             <ul style="list-style-type: none"> <li>• Transfer to occur in 1 min. or less.</li> <li>• Test for impaired function at room temperature.</li> <li>• See supporting record for further test details.</li> </ul> </li> </ol>	No	Pass	

Grp	Test Name Test Spec	Test Description	Deviate Y/N	Pass /Fail	Comments
A	Salt Spray Atmosphere (Operational)  J-1455 Aug94 Section 4.3.3 Ref. ASTM B 117-73	<ol style="list-style-type: none"> <li>1. Subject UUT under nominal conditions of voltage and load, to a solution of 5 parts salt to 95 parts water,</li> <li>2. Atomize at a temp. of 35°C,</li> <li>3. UUT to be exposed to salt spray for 48 hours,</li> <li>4. When concluded, gently rinse in clean running water, at 38°C to remove salt deposits from surface,</li> <li>5. Immediately dry with stream of compressed dry air at 175.8 – 241.3 kPa,</li> </ol> <ul style="list-style-type: none"> <li>• Inspect for surface corrosion and salt ingress.</li> <li>• Test for impaired function during and after test.</li> </ul>	No	Pass	
A	Steam Cleaning (Non-Operational)  J-1455 Aug94 Section 4.5.3 Page 17, Fig. 5,	<ol style="list-style-type: none"> <li>1. Place non-operating UUT in normal operating position.</li> <li>2. If integral connector is used, it shall be mated.</li> <li>3. <b>Deviate:</b> to EP455 Section 5.6 Level 1. UUT mounted with normally exposed surfaces exposed to wash stream.</li> <li>4. Use flat fan nozzles 20 – 30 cm away.</li> <li>5. Source pressure 1400kPa, flow rate of 9.46 litre/min. (150 gal/hr.).</li> <li>6. Use water at approximately 93°C.</li> <li>7. Deviate exposure from J-1455 to EP455 Section 5.6 Level 1. Expose UUT to sweeping spray over exposed surfaces for a period of 2 minutes.</li> </ol> <ul style="list-style-type: none"> <li>• Inspect for water ingress.</li> <li>• Test for impaired function at end of test.</li> </ul>	Yes	Pass	This test was performed in the test facility parking lot using an external mobile pressure wash system.



Grp	Test Name Test Spec	Test Description	Deviate Y/N	Pass /Fail	Comments
A	Chemical Exposure (Non-Operational)  EP455 Jul91 Section 5.8.2	<ol style="list-style-type: none"> <li>1. Apply the specified chemical solution with a brush until evenly coated over the normally exposed surface area.</li> <li>2. Repeat once per day for three days.</li> <li>3. Check for impaired function or detrimental corrosion during the test and at the end of a 100-hour minimal interval following exposure to test conditions.</li> </ol>	No	Pass	
B	Solar Radiation, Ultraviolet Effects (Non-Operational)  EP455 Jul91 Section 5.4.1	<ol style="list-style-type: none"> <li>1. UUT non-operational,</li> <li>2. Expose for 300 hours to UV light source of 280 to 400 nm wavelength,</li> <li>3. Distance of .75 metres from light source, <ul style="list-style-type: none"> <li>• Expose to a range of spectral energy from 43 to 75 W/m<sup>2</sup>,</li> <li>• <b>Test for impaired function at end of test.</b></li> </ul> </li> </ol>	No	Pass	
C	Random Vibration (Operational)  J-1455 Aug94 Section 4.9.4.2	<ol style="list-style-type: none"> <li>1. UUT operational,</li> <li>2. Test all three mutually perpendicular axes,</li> <li>3. Power spectral energy profiles to match the profiles as set out in J-1455, figure 10</li> <li>4. Vibration duration of 8 hours per axis <ul style="list-style-type: none"> <li>• <b>Test for impaired function during and at end of test.</b></li> </ul> </li> </ol>	No	Pass	
C	Operational Shock (Operational)  J-1455 Aug94 Section 4.10.3.4 Ref. EP455 5.14.1 page 296	<ol style="list-style-type: none"> <li>1. UUT operating during test</li> <li>2. Deviate to EP455 section 5.14.1</li> <li>3. Subject UUT to a single 11ms half sine pulse of 490m/s<sup>2</sup> in all 3 axes</li> <li>4. Inspect for physical damage <ul style="list-style-type: none"> <li>• <b>Test for impaired function during and at end of test.</b></li> </ul> </li> </ol>	Yes	Pass	

Grp	Test Name Test Spec	Test Description	Deviate Y/N	Pass /Fail	Comments
C	Pressure Washing (Non-Operational)  EP455 Jul91 Section 5.6 Level 1	<ol style="list-style-type: none"> <li>1. Place UUT in normal operating position</li> <li>2. If integral connector is used, it shall be mated</li> <li>3. Test apparatus, per EP455 5.6 Level 1</li> <li>4. Use flat fan nozzles 10 cm away</li> <li>5. Source pressure 7000kPa, flow rate of 15.9 litre/min</li> <li>6. <b>Deviate:</b> use water/detergent mixture at 40°C</li> <li>7. Expose to sweeping spray for 2 minute period                             <ul style="list-style-type: none"> <li>• Inspect for water ingress,</li> <li>• Test for impaired function at end of test.</li> </ul> </li> </ol>	Yes	Pass	
C	Installation Harness Shock (Non-Operational)  J-1455 Aug94 Section 4.11.3.3	<ol style="list-style-type: none"> <li>1. Allow non-operating UUT to free fall while attached to all harness connectors.</li> <li>2. Hold harness securely 1 metre from connector/product end</li> <li>3. Repeat 2 times,                             <ul style="list-style-type: none"> <li>• Inspect harness terminals or main relief area for damage.</li> </ul> </li> </ol>	No	Pass	
C	Handling Drop Test (Non-Operational)  J-1455 Aug94 Section 4.11.3.1	<ol style="list-style-type: none"> <li>1. Drop non-operational UUT 1 m onto a level concrete surface</li> <li>2. One time in each of the three mutually perpendicular surfaces</li> <li>3. Choose different impact surfaces for each sample to ensure every surface is impacted during the test                             <ul style="list-style-type: none"> <li>• Test for impaired function at end of test regardless of visible UUT damage</li> </ul> </li> </ol>	No	Pass	Connector shell damage may result if UUT is dropped such that the connector hits concrete first. UUT will continue to function electrically even with connector damage present. It is not recommended that a dropped unit showing connector damage be used for end customer applications.

Grp	Test Name Test Spec	Test Description	Deviate Y/N	Pass /Fail	Comments
C	Humidity Soak (Non-Operational)  EP455 Jul91 Section 5.13.2	<ol style="list-style-type: none"> <li>Set the chamber humidity to 96% RH.</li> <li>Place the UUT in the chamber and set the temperature to +38°C.</li> <li>Allow the UUT to remain in the chamber for 240 hours.                             <ul style="list-style-type: none"> <li>Inspect for physical damage.</li> <li>Test for impaired function at end of test.</li> </ul> </li> </ol>	No	Pass	
D	Humidity Cycling (Operational)  J-1455 Aug94 Section 4.2.3 Method 1 Page 13, Fig. 4a.	<ol style="list-style-type: none"> <li>Set the chamber humidity to 90% RH.</li> <li>Place the UUT in the chamber with temperature stabilized at +85°C.</li> <li>Attach test loads and apply 14VDC power to the UUT.</li> <li>Allow the UUT to remain at +85°C for 2 hours.</li> <li>Set the chamber temperature to -40°C and maintain the temperature for 2 hours.</li> <li>Set the chamber temperature to +38°C and maintain the temperature for 1 hour.</li> <li>Set the chamber temperature to +85°C and maintain the temperature for 30 minutes.</li> <li>Set the chamber temperature to ambient.                             <ul style="list-style-type: none"> <li>Temperature transition must be at an average rate of 1.5°C/minute.</li> <li>Test for impaired function during and at end of test.</li> </ul> </li> </ol>	No	Pass	
D	Operating Voltage (Operational)  J-1455 Aug94 Section 4.11.1.1.1	<p><b>12 Volt System</b></p> <ul style="list-style-type: none"> <li>Test UUT for impaired function while operating between 9 and 16 VDC.</li> <li><b>Deviate:</b> 6 V minimum continuous operating voltage</li> </ul> <p><b>24 Volt System</b></p> <ul style="list-style-type: none"> <li>Test UUT for impaired function while operating between 9 and 32 VDC.</li> <li><b>Deviate:</b> 6 V minimum continuous operating voltage</li> </ul>	Yes	Pass	Tested both 12 V and 24 V system levels

Grp	Test Name Test Spec	Test Description	Deviate Y/N	Pass /Fail	Comments
D	Starting Voltage (Operational)  EP455 Jul91 Section 5.10.6	<ul style="list-style-type: none"> <li>Test UUT for impaired function at 5.3 VDC after having ramped up from 0VDC.</li> </ul>	No	Pass	UUT was non-operational at 5.3 V since it is specified to operate from 6 V and up. No impaired function at 5.3 V was recorded.
D	Operational Power-up. (Operational)  EP455 Jul91 Section 5.10.7	<ul style="list-style-type: none"> <li>Test UUT for impaired function as its power source is ramped from 0 VDC to 6 VDC at a rate of 1V/msec.</li> <li>Repeat test but ramp from 0VDC to 28 VDC at a rate of .25 V/sec.</li> </ul>	No	Pass	
D	Jump Start (Operational)  J-1455 Aug94 Section 4.11.1.1.1	<p><b>12 Volt System</b></p> <ul style="list-style-type: none"> <li>Test UUT for impaired function while operating at +24 VDC for a period of 5 minutes.</li> </ul> <p><b>24 Volt System</b></p> <ul style="list-style-type: none"> <li>Test UUT for impaired function while operating at +48 VDC for a period of 5 minutes.</li> </ul>	No	Pass	Since the UUT is normally specified to operate at 24 V continuous, the test was conducted to 24 V levels only.
D	Reverse Polarity (Operational)  EP455 Jul91 Section 5.10.4 Modified for 24 volt system	<p><b>12 Volt System</b></p> <ul style="list-style-type: none"> <li>Test UUT for impaired function following exposure of -12VDC to its power source for 5 minutes.</li> <li>Test setup must include all normal loads connected to the UUT to provide a worst case test scenario.</li> </ul> <p><b>24 Volt System</b></p> <ul style="list-style-type: none"> <li>Test UUT for impaired function following exposure of -24VDC to its power source for 5 minutes.</li> <li>Test setup must include all normal loads connected to the UUT to provide a worst case test scenario.</li> </ul>	No	Pass	Both 12 V and 24 V levels were tested.  UUT outputs turn on in reverse battery mode. Short circuit protection is not available in reverse battery mode. If the load connected externally allows reverse currents higher than specified output ratings, the loads and/or UUT outputs may be damaged.

Grp	Test Name Test Spec	Test Description	Deviate Y/N	Pass /Fail	Comments
D	Short-Circuit Protection (Operational)  EP455 Jul91 Section 5.10.4 Modified for 24 volt system	<ul style="list-style-type: none"> <li>Test UUT for impaired function after shorting each external lead to system ground and maximum continuous system battery voltage for a period of <b>5 minutes</b> with all protection systems in place.</li> <li><b>Deviate:</b> Maximum system battery voltage = +32 VDC</li> </ul>	Yes	Pass	At the time and date that this test was performed, the UUT software was designed to restart outputs shorted to ground every 5 seconds.
D	Alternator Field Decay (Non-Operational)  EP455 Jul91 Section 5.11.2	<ul style="list-style-type: none"> <li>Test UUT for impaired function after power line exposure to a transient of <math>-90e^{-t/0.038}</math> V</li> <li><b>Deviate:</b> Source impedance = 10Ω,</li> <li>The test shall be repeated at a rate of 0.2 Hz for 60 test cycles</li> <li>Test UUT for impaired function after exposure to test pulse</li> </ul>	Yes	Pass	This test disconnects the battery voltage from the UUT at the time the pulse is energized and remains off for a period of 200 ms. The UUT may reset during this period, but must function properly when power returns.
D	Inductive Load Switching Transient (Operational)  J-1455 Aug94 Section 4.11.2.2.2	<ul style="list-style-type: none"> <li>UUT operational</li> <li><b>12 Volt System</b></li> <li>Apply to the power source <math>14 \pm 600e^{\pm t/0.001}</math> V,</li> <li><b>Deviate:</b> Source impedance of 10Ω</li> <li>The test shall be repeated for 10 pulses at 1 sec. Intervals.</li> <li><b>24 Volt System</b></li> <li>Apply to the power source <math>28 \pm 600e^{\pm t/0.001}</math> V,</li> <li><b>Deviate:</b> Source impedance of 10Ω</li> <li>The test shall be repeated for 10 pulses at 1 sec. Intervals.</li> <li>No impaired function occurs during or at end of either test.</li> </ul>	Yes	Pass	J1455 defines a total of 10 inductive load pulses, which is what the UUT is designed to meet. It is recommended that any inductive elements connected to the product (particularly to product inputs) in actual applications be suppressed with suppression transorbs or diodes.

Grp	Test Name Test Spec	Test Description	Deviate Y/N	Pass /Fail	Comments
D	Load Dump Transient (Operational)  J-1455 Aug94 Section 4.11.2.2.1  Ref: ISO 7637	<ul style="list-style-type: none"> <li>UUT operational,</li> </ul> <p><b>12 Volt System</b></p> <ul style="list-style-type: none"> <li><b>Deviate:</b> Apply to the power source <math>14 + 86e^{-t/0.133}</math> V (based on ISO pulse 5)</li> <li><b>Deviate:</b> Source impedance of <math>.5\Omega</math></li> <li><b>Deviate:</b> The test shall be repeated for 5 pulses at 90 sec. intervals</li> <li>No impaired function occurs during or at end of test.</li> </ul> <p><b>24 Volt System</b></p> <ul style="list-style-type: none"> <li><b>Deviate:</b> Apply to the power source <math>28 + 122e^{-t/0.133}</math> V (based on ISO pulse 5)</li> <li><b>Deviate:</b> Source impedance of <math>1\Omega</math></li> <li><b>Deviate:</b> The test shall be repeated for 5 pulses at 90 sec. intervals,</li> <li>No impaired function occurs during or at end of test.</li> </ul>	Yes	Pass	Transient generator equipment is designed for ISO pulse generation. Load dump pulse deviated to ISO specified decay rates. Refer to ISO pulse 5 in ISO 7637 specifications.
E	Accessory Noise  EP455 Jul91 Section 5.11.1	<ul style="list-style-type: none"> <li>UUT Operational</li> <li>Apply a voltage of <math>14 + 1.5 \sin(2\pi f \cdot t)</math>, where frequency f is to be swept from 50Hz - 10 kHz over a 5min period</li> <li><b>Deviate:</b> Add 24V system test where voltage applied is <math>28 + 1.5 \sin(2\pi f \cdot t)</math></li> <li><b>Deviate:</b> Source impedance is less than <math>1\Omega</math></li> <li>Test throughout exposure for impaired function.</li> </ul>	Yes	Pass	24V testing for accessory noise is not defined by EP455. A 24 V system version has been defined as deviations to the EP455 specification

Grp	Test Name Test Spec	Test Description	Deviate Y/N	Pass /Fail	Comments
E	Batteryless Operation  EP455 Jul91 Section 5.11.3 Level 1	<ul style="list-style-type: none"> <li>• UUT operational,</li> <li>• Apply a voltage of <math>6 +  12.6 \sin(2\pi f \cdot t) </math>, where frequency <math>f</math> is to be swept from 500 Hz - 1.5 kHz over a 5min period,</li> <li>• <b>Deviate:</b> Add 24 V system test where voltage applied is <math>6 +  25.2 \sin(2\pi f \cdot t) </math></li> <li>• <b>Deviate:</b> Source impedance is less than <math>2.5\Omega</math></li> <li>• Test throughout exposure for impaired function.</li> </ul>	Yes	Pass	24 V testing for batteryless operation is not defined by EP455. A 24 V system version has been defined as deviations to the EP455 specification
E	Radiated Emissions (Operational) In House  J-1455 Aug94 Section 4.11.3.3.1 Ref: J-1113/41 Jul95	<ul style="list-style-type: none"> <li>• Setup product with test harness, inputs and loads in EMC Chamber according to J1113/41 Jul95 figures 8 and 9</li> <li>• Expose 1.5 metres of harness in front of EMC antenna</li> <li>• Distance from antenna to harness is 1 metre</li> <li>• Antenna located in center of 1.5 metre harness length</li> <li>• <b>Deviate:</b> Chamber size is 3 m x 3 m x 3 m. Chamber wall to antenna distance is &lt; 1m in some instances.</li> <li>• Apply 14 V power to the product and while operating in a normal manner capture radiated noise from 9 kHz to 1 GHz (vertical and horizontally polarized where applicable)</li> <li>• Capture plots of emissions based over full test bandwidth.</li> </ul>	Yes	Pass	<p>Pass criteria defined as follows:</p> <p>Narrow Band Class 2 from 9 kHz to 70 MHz</p> <p>Narrow Band Class 1 from 70 MHz to 90 MHz</p> <p>Narrow Band Class 2 from 90 MHz to 1 GHz</p> <p>Where broad band noise above narrow band limits is found, broadband testing and limit lines are to be used.</p>

Grp	Test Name Test Spec	Test Description	Deviate Y/N	Pass /Fail	Comments
E	Radiated Susceptibility (Operational) In House  J-1455 Aug94 Section 4.11.3.3.2 Ref: J-1113/21 J-1113-1	<ul style="list-style-type: none"> <li>• Setup product with test harness, inputs and loads in EMC Chamber</li> <li>• Expose 1.5 metres of harness in front of EMC antenna</li> <li>• Distance from antenna to harness is 1 metre</li> <li>• Antenna located in centre of 1.5 metre harness length</li> <li>• <b>Deviate:</b> Chamber size is 3 m x 3 m x 3 m. Chamber wall to antenna distance is &lt; 1m in some instances.</li> <li>• Apply 14 V power to the product and operating in a normal manner</li> <li>• Apply frequency sweeps from 9 kHz to 1 GHz horizontal and vertical polarization at levels of 50 V/m. Antenna types will vary depending on frequency band being tested.</li> <li>• Test full sweep with continuous wave (no modulation)</li> <li>• Repeat full sweep with 80% amplitude modulated (AM) 1 kHz waveform</li> <li>• Test product for impaired operation during and following test</li> </ul>	Yes	Pass	Pass criteria defined as follows: UUT shall be considered Class C UUT Shall conform to the following levels: Level II <= 50 V/m For definition of classes, levels and regions refer to SAE J1113-1 Jul95
E	Mutual Coupling (Operational)  J-1455 Aug94 Section 4.11.2.2.3	<ul style="list-style-type: none"> <li>• UUT operational</li> </ul> <p><b>12 Volt System</b></p> <ul style="list-style-type: none"> <li>• Subject to the UUT's power source <math>14 \pm 300e^{-t/(15 \times 10^{-6})}</math> V,</li> <li>• Source impedance of 50Ω</li> <li>• The test shall be repeated for 10 pulses at 1sec intervals</li> <li>• No impaired function or UUT damage occurs following test</li> </ul> <p><b>24 Volt System</b></p> <ul style="list-style-type: none"> <li>• Subject to the UUT's power source <math>28 \pm 300e^{-t/(15 \times 10^{-6})}</math> V,</li> <li>• Source impedance of 50Ω</li> <li>• The test shall be repeated for 10 pulses at 1sec. Intervals,</li> <li>• No impaired function or UUT damage occurs following test</li> </ul>	No	Pass	



Grp	Test Name Test Spec	Test Description	Deviate Y/N	Pass /Fail	Comments
E	Electrostatic Discharge Handling (Non-Operational)  J-1455 Aug94 Section 4.11.2.2.5.1 Ref: J-1113/13 section 5 pages 9 - 11	<ul style="list-style-type: none"> <li>• Set up per SAE J1113/13</li> <li>• UUT non-operational,</li> <li>• Temp. 20°C ± 3°C,</li> <li>• RH 20% - 50%,</li> <li>• Discharge a 150 pF capacitor through a 2KΩ resistor at the following voltage levels ±15 k</li> <li>• Apply ESD to each connector pin, and 10 predefined case locations</li> <li>• Use a wire 14 AWG to 20 AWG to access recessed pins. Wire to be solid core and no more than 25 mm long,</li> <li>• Each discharge point shall be subjected to a minimum of 3 positive and 3 negative polarity discharges at each voltage level,</li> <li>• Each ESD pulse shall be followed by a discharge of the UUT pin/surface through a 1 MΩ resistance to ground</li> <li>• Duration between charges shall be 5 seconds minimum,</li> <li>• Test for impaired function prior to start of test and at end of each individual test.</li> </ul>	No	Pass	

Grp	Test Name Test Spec	Test Description	Deviate Y/N	Pass /Fail	Comments
E	Electrostatic Discharge In Vehicle (Operational)  J-1455 Aug94 Section 4.11.2.2.5.2 Ref: J1113/13 section 4 pages 6 - 8	<ul style="list-style-type: none"> <li>• Set up per SAE J1113/13</li> <li>• UUT operational</li> <li>• Temp. 20°C ± 3°C</li> <li>• RH 20% - 50%</li> <li>• Each exposed IO pin at the end of the UUT test harness shall be tested for direct contact and air discharge</li> <li>• ESD gun setup with a 330 pF capacitor through a 2KΩ resistor at the following voltage levels ±15 kV</li> <li>• Each discharge point shall be subjected to a minimum of 3 positive and 3 negative polarity discharges at each voltage level</li> <li>• Each ESD pulse shall be followed by a discharge of the UUT pin/surface through a 1 MΩ resistance to ground</li> <li>• Duration between charges shall be 5 seconds minimum</li> <li>• Test for impaired function prior to start of test and at end of each individual test.</li> </ul>	No	Pass	

## 7. VMM Connectors

---

The VMM2820 has connectors for inputs and outputs.

### 7.1. Input Connectors

There are two input connectors in the VMM2820 (J1 and J2) as shown in the figure below:

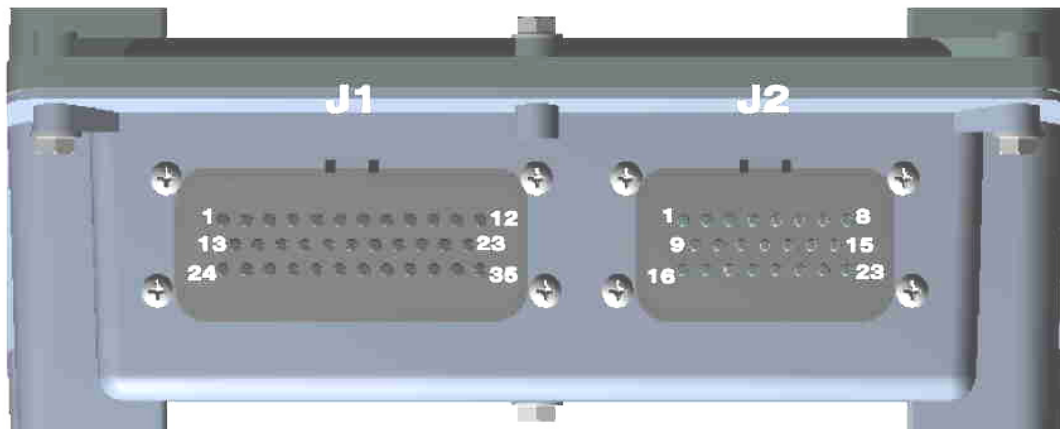

Input connectors (J1 and J2)

#### 7.1.1. 35 Pin Input Connector (J1)

The following part numbers are used for the 35-pin (J1) connector:

- 35PIN VMM Connector: AMP P/N 1-776163-1
- Mating Connector: AMP P/N 776164-1
- Mating Terminals: AMP P/N 770854-3

The following table shows the pin-out for the 35-pin input connector:

**35 pin input connector pin-out**

Pin #	Pin Function
1	Input 1
2	Input 2
3	Input 3
4	Input 4
5	Input 5
6	Input 6
7	Input 7
8	Input 8
9	Input 9
10	Input 10
11	Input 11
12	Input 12
13	Address 1
14	Address 2
15	Address 3
16	Address 4
17	Address 5
18	Analog Input 1
19	Analog Input 2
20	Reserved
21	Reserved
22	Reserved
23	Reserved
24	+Vbatt
25	+Vbatt
26	+Vbatt
27	GND
28	GND
29	GND
30	GND
31	CAN Shield
32	CAN High
33	CAN Low
34	Reserved
35	Reserved

### 7.1.2. 23 Pin Input Connector (J2)

The following part numbers are used for the 23-pin (J2) connector:

- 23PIN VMM Connector: AMP P/N 1-776087-1
- Mating Connector: AMP P/N 770680-1
- Mating Terminals: AMP P/N 770854-3

The following table shows the pin-out for the 23-pin input connector:

**23 pin input connector pin-out**

Pin #	Pin Function
1	Input 13
2	Input 14
3	Input 15
4	Input 16
5	Input 17
6	Input 18
7	Input 19
8	Input 20
9	Input 21
10	Input 22
11	Input 23
12	Input 24
13	Input 25
14	Input 26
15	Input 27
16	Input 28
17	Analog Input 3
18	Reserved
19	Reserved
20	Reserved
21	Reserved
22	Reserved
23	Reserved

## 7.2. Output Connectors

There are two output connectors in the VMM 2820 (J3 and J4) as shown in the figure below:

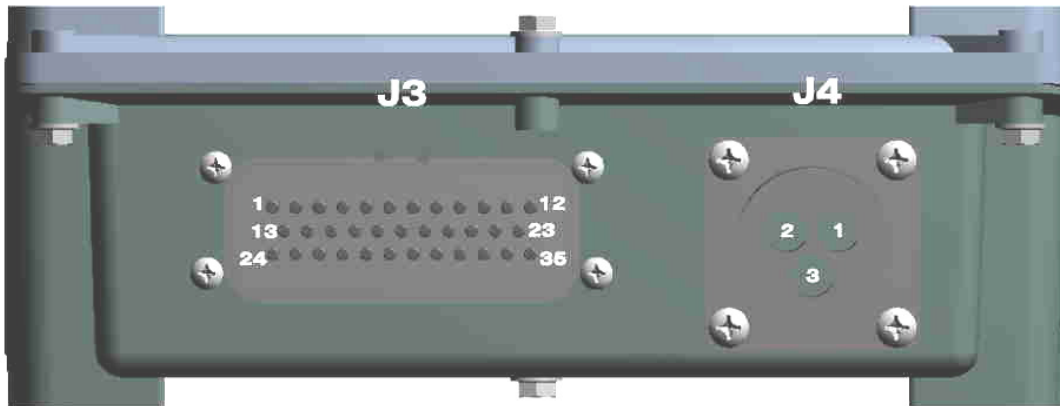

**Output Connectors (J3 and J4)**

### 7.2.1. 35 pin output connector (J3)

The following part numbers are used for the 35-pin (J3) connector:

- 35PIN VMM Connector: AMP P/N 1-776163-1
- Mating Connector: AMP P/N 776164-1
- Mating Terminals: AMP P/N 770854-3

The following table shows the pin-out for the 35-pin output connector:

#### 35 pin output connector pin-out

Pin #	Pin Function	Output Bus Bar
1	Output 6	1
2	Output 5	1
3	Output 4	1
4	Output 3	1
5	Output 2	1
6	Output 1	1
7	Output 10	2
8	Output 11	2
9	Output 12	2
10	Output 13	2
11	Output 14	2
12	Output 15	2
13	Output 7	1
14	Reserved	N/A
15	Reserved	N/A
16	Reserved	N/A
17	Reserved	N/A

Pin #	Pin Function	Output Bus Bar
18	Reserved	N/A
19	Reserved	N/A
20	Reserved	N/A
21	Reserved	N/A
22	Reserved	N/A
23	Output 16	2
24	Output 8	1
25	Output 9	1
26	Output 19 A	N/A
27	Output 19 B	N/A
28	Reserved	N/A
29	Reserved	N/A
30	Reserved	N/A
31	Reserved	N/A
32	Output 20 B	N/A
33	Output 20 A	N/A
34	Output 18	2
35	Output 17	2

### 7.2.2. 3 pin output connector

The following part numbers are used for the 3-pin (J4) connector:

- 3PIN VMM Connector: AMP P/N 213899-2
- Mating Connector: AMP P/N 213905-1
- Mating Terminals: AMP P/N 213841-3

The following table shows the pin-out for the 3-pin output connector:

#### 3 pin output connector pin-out

Pin #	Pin Function
1	Bus bar for outputs 1 to 9
2	Bus bar for outputs 10 to 18
3	Reserved
1	Bus bar for outputs 1 to 9





## 8. Feedback

---

In order to ensure the manual meets your needs, we need your feedback. Please answer the questions on this page and then fax the page to the **Marketing Services** group at Vansco Electronics LP. Or, use the e-mail address shown below to send us your comments.

**Mailing address:** Vansco Electronics LP  
1305 Clarence Ave  
Winnipeg MB R3T 1T4  
Canada

**Fax:** 204.478.1749

**E-mail:** [info@vansco.ca](mailto:info@vansco.ca)

1. What is your comfort level with the subject matter?  
Beginner — Intermediate — Advanced — Professional
2. How would you rate the quality of this manual?  
1 (low) — 2 — 3 — 4 — 5 (high)
3. What do you like about this manual?
  
4. What do you dislike about this manual?

